

Register your instrument!
www.eppendorf.com/myeppendorf



Centrifuge 5702/5702 R/5702 RH

Operating manual

Copyright © 2017 Eppendorf AG, Germany. All rights reserved, including graphics and images. No part of this publication may be reproduced without the prior permission of the copyright owner.

Centriplus® is a registered trademark of Millipore Corporation, USA.

CombiSlide® is a registered trademark of Eppendorf AG, Germany.

Eppendorf® and the Eppendorf Brand Design are registered trademarks of Eppendorf AG, Germany.

Registered trademarks and protected trademarks are not marked in all cases with ® or ™ in this manual.

U.S. Patents are listed on www.eppendorf.com/ip.

Table of contents

1	Operating instructions	7
1.1	Using this manual	7
1.2	Danger symbols and danger levels	7
1.2.1	Danger symbols	7
1.2.2	Danger levels	7
1.3	Symbols used	8
1.4	Abbreviations used	8
2	Safety	9
2.1	Intended use	9
2.2	User profile	9
2.3	Information on product liability	9
2.4	Application limits	9
2.4.1	Declaration concerning the ATEX directive (2014/34/EU)	9
2.5	Warnings for intended use	10
2.5.1	Personal injury or damage to the equipment	10
2.5.2	Incorrect handling of the centrifuge	11
2.5.3	Incorrect handling of the rotors	12
2.5.4	Extreme strain on the centrifuging tubes	13
2.6	Safety instructions on the device	13
3	Product description	15
3.1	Product overview	15
3.1.1	Centrifuge 5702	15
3.1.2	Centrifuge 5702 R / RH	16
3.2	Delivery package	17
3.3	Features	17
3.4	Name plate	19
4	Installation	21
4.1	Selecting the location	21
4.2	Preparing installation	22
4.3	Installing the instrument	23
5	Operation	25
5.1	Operating controls	25
5.2	Switching on the centrifuge	28
5.3	Replacing the rotor	28
5.3.1	Inserting the rotor	28
5.3.2	Removing the rotor	28
5.4	Loading a fixed-angle rotor	29
5.5	Loading a swing-bucket rotor	30
5.5.1	Inserting the bucket in the swing-bucket rotor	30
5.5.2	Performing an imbalance calibration	30
5.5.3	Loading the buckets symmetrically	31
5.6	Closing the centrifuge lid	33
5.7	Aerosol-tight centrifugation	33
5.7.1	Aerosol-tight centrifugation in a swing-bucket rotor	33

Table of contents

Centrifuge 5702/5702 R/5702 RH
English (EN)

5.8	Centrifugation	34
5.8.1	Centrifugation with time setting	34
5.8.2	Centrifuging in continuous operation	35
5.8.3	Short run centrifugation	35
5.8.4	Setting a soft ramp	36
5.8.5	Setting the beginning of time counting (At set rpm function)	36
5.8.6	Calculating the speed of centrifugation	37
5.9	Centrifuge 5702 R, Centrifuge 5702 RH: Heating and cooling.	37
5.9.1	Setting the temperature	37
5.9.2	Temperature display	38
5.9.3	Temperature monitoring	38
5.9.4	Temperature control run FastTemp.	38
5.9.5	Continuous cooling	39
5.9.6	Centrifuge 5702 RH: Temperature profiles	40
5.10	Switching off the centrifuge	40
6	Device settings	41
6.1	Changing the operating state	41
6.2	Key lock.	41
6.2.1	Centrifuge 5702 R, Centrifuge 5702 RH: Securing the program against any changes	42
6.2.2	Centrifuge 5702: Displaying the key lock status.	42
6.3	Speakers	42
6.3.1	Display the status of the speakers.	42
7	Programs	43
7.1	Creating and storing a program	43
7.2	Saving the current settings as a program	43
7.3	Calling up a program.	44
7.4	Editing programs	44
7.5	Deleting programs.	44
7.6	Exiting the program	44
8	Maintenance	45
8.1	Service.	45
8.2	Prepare cleaning/disinfection	45
8.3	Cleaning/disinfection	46
8.3.1	Cleaning and disinfecting the device	47
8.3.2	Disinfecting and cleaning the rotor.	47
8.4	Additional care instructions for refrigerated centrifuges	48
8.5	Cleaning glass breakage	48
8.6	Replacing the fuses	49
8.7	Decontamination before shipment	49
9	Troubleshooting	51
9.1	General errors	51
9.2	Error messages	52
9.3	Emergency release	55

10	Transport, storage and disposal	57
10.1	Transport	57
10.2	Storage	57
10.3	Disposal	58
11	Technical data	59
11.1	Power supply	59
11.2	Weight/dimensions	59
11.3	Noise level	60
11.4	Ambient conditions	60
11.5	Application parameters	61
11.6	Acceleration and deceleration times	62
11.7	Service life for accessories	63
12	Rotors, tubes and adapters	65
12.1	Rotor A-4-38	65
12.1.1	Rotor A-4-38 with 4 round buckets	65
12.1.2	Rotor A-4-38 with 4 rectangular buckets	68
12.2	Rotor A-8-17	70
12.3	Rotor F-45-24-11	71
12.4	Rotor F-35-30-17	72
12.5	Rotor F-45-18-17-Cryo	73
13	Ordering information	75
13.1	Rotor A-4-38	75
13.1.1	Rotor A-4-38 with round buckets	75
13.1.2	Rotor A-4-38 with rectangular buckets	76
13.2	Rotor A-8-17	76
13.3	Rotor F-45-24-11	77
13.4	Rotor F-35-30-17	77
13.5	Rotor F-45-18-17-Cryo	78
13.6	Fuses	78
	Index	79
	Annex	81
	Certificates	83

Table of contents

Centrifuge 5702/5702 R/5702 RH
English (EN)

1 Operating instructions







1.1 Using this manual

- ▶ Read this operating manual completely before using the device for the first time. Also observe the instructions for use of the accessories.
- ▶ A detailed description of the device is also contained in the English and German versions of this operating manual.
- ▶ This operating manual is part of the product. Thus, it must always be easily accessible.
- ▶ Enclose this operating manual when transferring the device to third parties.
- ▶ You will find the current version of the operating manual for all available languages on our website under www.eppendorf.com/manuals.

1.2 Danger symbols and danger levels

1.2.1 Danger symbols

The safety instructions in this manual appear with the following danger symbols and danger levels:

	Biohazard		Explosive substances
	Electric shock		Risk of crushing
	Hazard point		Material damage

1.2.2 Danger levels

DANGER	<i>Will</i> lead to severe injuries or death.
WARNING	<i>May</i> lead to severe injuries or death.
CAUTION	<i>May</i> lead to light to moderate injuries.
NOTICE	<i>May</i> lead to material damage.

Operating instructions

Centrifuge 5702/5702 R/5702 RH
English (EN)

1.3 Symbols used

Depiction	Meaning
1. 2.	Actions in the specified order
▶	Actions without a specified order
•	List
<i>Text</i>	Display text or software text
i	Additional information

1.4 Abbreviations used**PCR**

Polymerase chain reaction

rcf

Relative centrifugal force – Relative centrifugal force: g -force in m/s^2

rpm

Revolutions per minute – Revolutions per minute

UV

Ultraviolet radiation

2 Safety

2.1 Intended use

The Centrifuge 5702/5702 R/5702 RH is designed for separating liquid substance mixtures with different densities, in particular, for processing and analyzing samples from the human body in in-vitro diagnostic applications to ensure that the in-vitro diagnostic device can be used according to its intended purpose. This centrifuge including components is an in-vitro diagnostic device according to Directive 98/79/EC of the European Parliament and the Council dated October 27, 1998.

Eppendorf centrifuges are exclusively intended for indoor use by trained specialists.

2.2 User profile

The device and accessories may only be operated by trained and skilled personnel.

Before using the device, read the operating manual carefully and familiarize yourself with the device's mode of operation.

2.3 Information on product liability

In the following cases, the designated protection of the device may be compromised. Liability for any resulting property damage or personal injury is then transferred to the operator:

- The device is not used in accordance with the operating manual.
- The device is used outside of its intended use.
- The device is used with accessories or consumables which are not recommended by Eppendorf.
- The device is maintained or repaired by people not authorized by Eppendorf.
- The user makes unauthorized changes to the device.

2.4 Application limits

2.4.1 Declaration concerning the ATEX directive (2014/34/EU)



DANGER! Risk of explosion.

- ▶ Do not operate the device in areas where work is completed with explosive substances.
- ▶ Do not use this device to process any explosive or highly reactive substances.
- ▶ Do not use this device to process any substances which could create an explosive atmosphere.

Due to its design and the environmental conditions inside the device, the Centrifuge 5702/5702 R/5702 RH is not suitable for use in a potentially explosive atmosphere.

The device may only be used in a safe environment, such as in the open environment of a ventilated laboratory or a fume hood. The use of substances that may contribute to a potentially explosive atmosphere is not permitted. The final decision on the risks associated with the use of such substances lies with the user.

2.5 Warnings for intended use

2.5.1 Personal injury or damage to the equipment



WARNING! Electric shock due to damage to device or mains cable.

- ▶ Only switch on the device if the device and mains cable are undamaged.
- ▶ Only use devices that have been properly installed or repaired.
- ▶ In case of danger, disconnect the device from the mains supply. Disconnect the mains/power plug from the device or the earth/grounded socket. Use the designated isolating device (e.g., emergency switch in the lab).



WARNING! Lethal voltages inside the device.

Touching parts which are under high voltage may cause an electric shock. An electric shock injures the heart and causes respiratory paralysis.

- ▶ Ensure that the housing is closed and undamaged.
- ▶ Do not remove the housing.
- ▶ Ensure that no liquid can penetrate into the device.

Only authorized service staff may open the device.



WARNING! Risk from incorrect supply voltage

- ▶ Only connect the device to voltage sources which correspond to the electrical requirements on the name plate.
- ▶ Only use sockets with a protective earth (PE) conductor and suitable mains/power cord.



WARNING! Damage to health due to infectious liquids and pathogenic germs.

- ▶ When handling infectious liquids and pathogenic germs, observe the national regulations, the biological security level of your laboratory, the Material Safety Data Sheets, and the manufacturer's application notes.
- ▶ Use aerosol-tight sealing systems for the centrifugation of these substances.
- ▶ When working with pathogenic germs belonging to a higher risk group, more than one aerosol-tight bioseal must be used.
- ▶ Wear your personal protective equipment.
- ▶ For comprehensive regulations about handling germs or biological material of risk group II or higher, please refer to the "Laboratory Biosafety Manual" (source: World Health Organization, Laboratory Biosafety Manual, in its respectively current valid version).



WARNING! Risk of injury when opening or closing the centrifuge lid.

There is a risk of crushing your fingers when opening or closing the centrifuge lid.

- ▶ When opening or closing the centrifuge lid, do not reach between the lid and device or into the latching mechanism of the lid.
- ▶ Always open the centrifuge lid completely to prevent it from falling.



WARNING! Risk of injury from chemically or mechanically damaged accessories.

Even minor scratches and cracks can lead to severe internal material damage.

- ▶ Protect all accessory parts from mechanical damage.
- ▶ Inspect the accessories for damage before each use. Replace any damaged accessories.
- ▶ Do not use any accessories which have exceeded their maximum service life.



CAUTION! Poor safety due to incorrect accessories and spare parts.

The use of accessories and spare parts other than those recommended by Eppendorf may impair the safety, functioning and precision of the device. Eppendorf cannot be held liable or accept any liability for damage resulting from the use of incorrect or non-recommended accessories and spare parts, or from the improper use of such equipment.

- ▶ Only use accessories and original spare parts recommended by Eppendorf.



NOTICE! Damage to device due to spilled liquids.

1. Switch off the device.
2. Disconnect the device from the mains/power supply.
3. Carefully clean the device and the accessories in accordance with the cleaning and disinfection instructions in the operating manual.
4. If a different cleaning and disinfecting method is to be used, contact Eppendorf AG to ensure that the intended method will not damage the device.



NOTICE! Damage to electronic components due to condensation.

Condensate can form in the device after it has been moved from a cool environment to a warmer environment.

- ▶ After installing the device, wait for at least 3 h. Only then connect the device to the mains/power line.

2.5.2 Incorrect handling of the centrifuge



NOTICE! Damage from knocking against or moving the device during operation.

If the rotor bangs against the rotor chamber wall, it will cause considerable damage to the device and rotor.

- ▶ Do not move or knock against the device during operation.

2.5.3 Incorrect handling of the rotors

**WARNING! Risk of injury from improperly attached rotors and rotor lids.**

- ▶ Only centrifuge with rotor and rotor lid firmly tightened.
 - ▶ If there are any unusual noises when the centrifuge is started up, the rotor or rotor lid may not be properly attached. Immediately press the start/stop key to stop centrifuging.
-

**CAUTION! Risk of injury due to asymmetric loading of the rotor.**

- ▶ Load rotors symmetrically with identical tubes.
 - ▶ Only load adapters with suitable tubes.
 - ▶ Always use the same type of tubes (weight, material/density and volume).
 - ▶ Check symmetric loading by balancing the adapters and tubes used with scales.
-

**CAUTION! Risk of injury from overloaded rotor.**

The centrifuge is designed for the centrifugation of material with a maximum density of 1.2 g/mL at maximum speed and filling volume and/or load.

- ▶ Do not exceed the maximum load of the rotor.
-

**NOTICE! Damage to rotors from aggressive chemicals.**

Rotors are high-quality components which withstand extreme stresses. This stability can be impaired by aggressive chemicals.

- ▶ Avoid the use of aggressive chemicals, including strong and weak alkalis, strong acids, solutions with mercury, copper and other heavy metal ions, halogenated hydrocarbons, concentrated saline solutions and phenol.
 - ▶ Due to the manufacturing process, color variations may occur on rotors marked "coated". These color variations do not effect service life or resistance to chemicals.
-

**NOTICE! If handled incorrectly, the rotor may fall.**

The swing-bucket rotor may fall if the buckets are used as handles.

- ▶ Remove the buckets before inserting and/or removing a swing-bucket rotor.
 - ▶ Always use both hands to carry the rotor cross.
-

2.5.4 Extreme strain on the centrifuging tubes



CAUTION! Risk of injury from overloaded tubes.

- ▶ Note the loading limits specified by the tube manufacturer.
- ▶ Only use tubes which are approved by the manufacturer for the required *g*-force (rcf).



NOTICE! Risk from damaged tubes.

Damaged tubes must not be used, as this could cause further damage to the device and the accessories and loss of the samples.

- ▶ Before use, visually check all of the tubes for damage.



NOTICE! Risk from open tube lids.

Open tube lids can break off during centrifugation and damage both the rotor and the centrifuge.

- ▶ Carefully seal all tube lids before centrifuging.



NOTICE! Hazard to plastic tubes from organic solvents.

The density of plastic tubes is reduced when organic solvents (e.g., phenol, chloroform) are used, i.e. the tubes could become damaged.

- ▶ Note the manufacturer's information on the chemical resistance of the tubes.

2.6 Safety instructions on the device

Symbol	Meaning	Location
	<p>Hazard point</p> <ul style="list-style-type: none"> ▶ Observe operating manual. 	Rear of the device

Safety

Centrifuge 5702/5702 R/5702 RH
English (EN)

3 Product description
3.1 Product overview
3.1.1 Centrifuge 5702

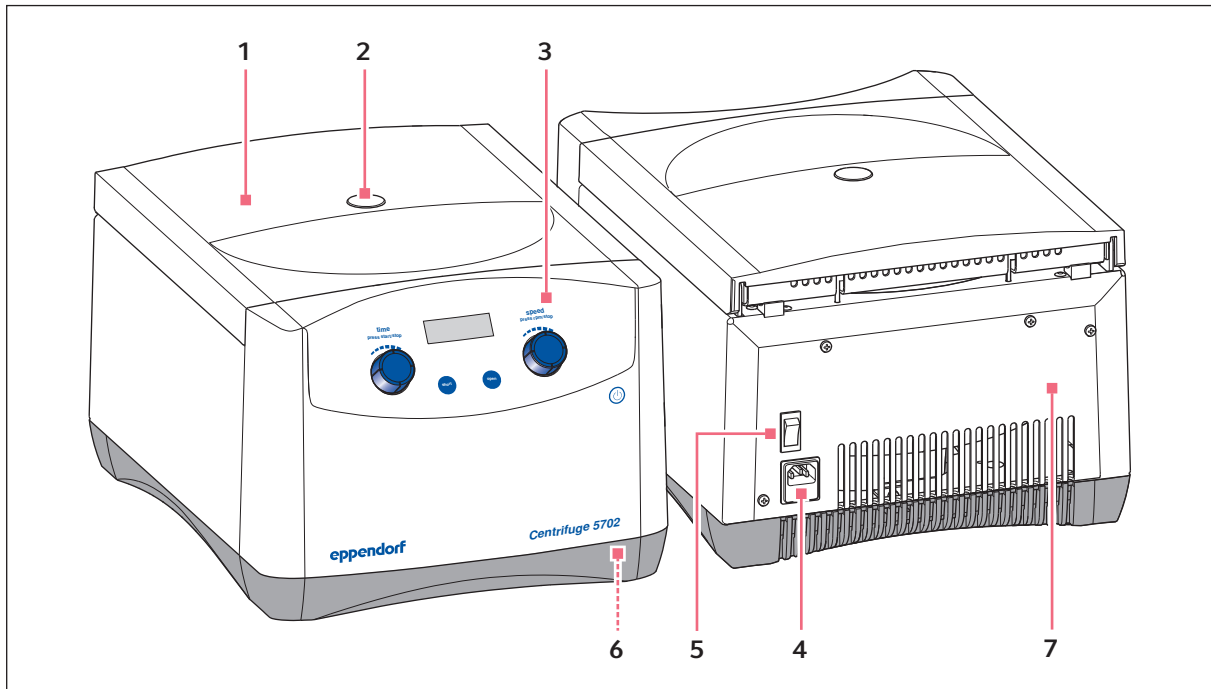

Fig. 3-1: Centrifuge 5702

- | | |
|---|--|
| 1 Centrifuge lid | 5 Mains/power switch
Switch for switching the centrifuge on and off. |
| 2 Monitoring glass
Visual inspection for rotor stop and/or facility for a speed check using a stroboscope | 6 Emergency release |
| 3 Control panel
Display, rotary knobs and keys for operating the centrifuge | 7 Name plate |
| 4 Mains/power cord socket
Connection for the mains/power cord supplied | |

Product description

Centrifuge 5702/5702 R/5702 RH
English (EN)

3.1.2 Centrifuge 5702 R / RH

Fig. 3-2: Centrifuge 5702 R / RH

- | | |
|---|---|
| <p>1 Centrifuge lid</p> <p>2 Monitoring glass
Visual inspection for rotor stop and/or facility for a speed check using a stroboscope.</p> <p>3 Control panel
Display, rotary knobs and keys for operating the centrifuge.</p> <p>4 Mains/power cord socket
Connection for the mains/power cord supplied</p> | <p>5 Mains/power switch
Switch for switching the centrifuge on and off.</p> <p>6 Emergency release</p> <p>7 Name plate</p> <p>8 Condensation water tray
For collecting the condensation water from the device</p> |
|---|---|

3.2 Delivery package

1	Centrifuge 5702/5702 R/5702 RH
1	Rotor key
1	Mains/power cord
1	Condensation water tray for Centrifuge 5702 R and Centrifuge 5702 RH
1	Set of fuses
1	Operating Manual

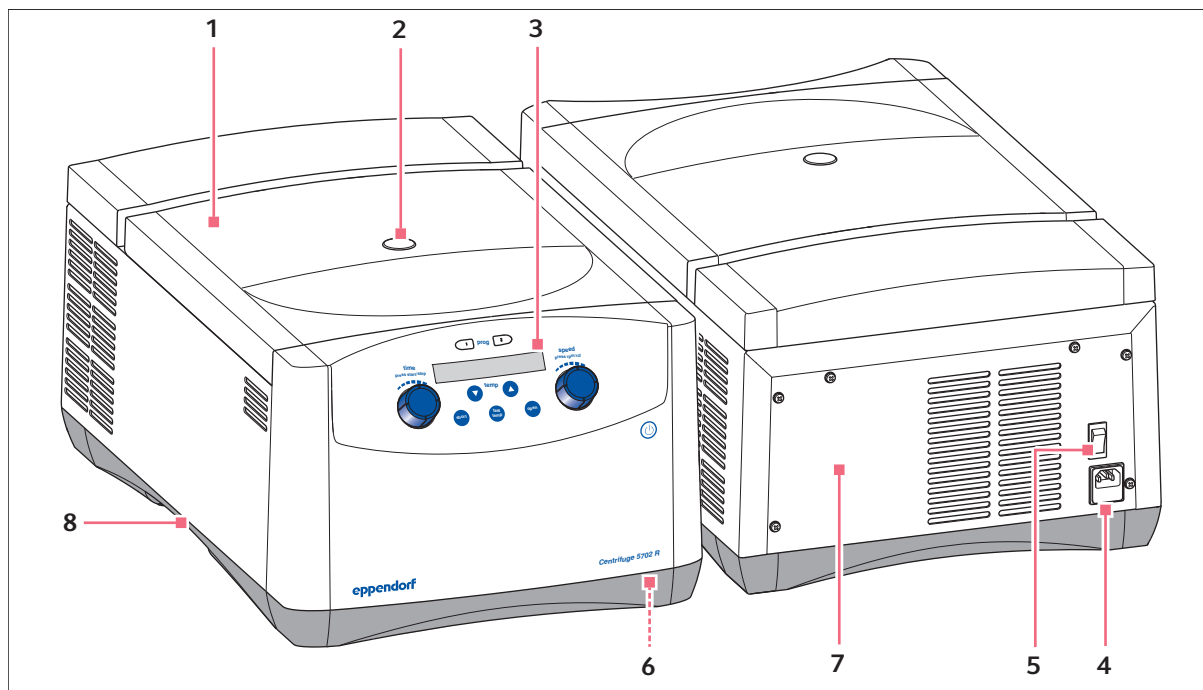

- ▶ Check the delivery for completeness.
- ▶ Check all parts for damage in transit.
- ▶ To safely transport and store the device, keep the transport box and packing material.

3.3 Features

The low-speed centrifuge family 5702 has been especially developed for cell culture laboratories and clinical research laboratories with a low to medium throughput. Due to their compact design these centrifuges fit on nearly all types of lab bench and their quiet operation improves your work environment. They can be operated with six different rotor options to accommodate nearly all types of tubes.

The right model for your application:

- Centrifuge 5702 for standard applications
- Cooled model Centrifuge 5702 R for samples which are sensitive to heat
- The cooled and heated model Centrifuge 5702 RH enables centrifuging in the area of molecular biology, improves the viability of the cells, resulting in more accurate results in subsequent applications (e.g. for cell cultivation).

Product features

- Maximum speed: 3000 × g (4 400 rpm)
- Very compact footprint – fits on any lab bench
- Very quiet operation for a better work environment
- Low height of the device makes loading and unloading of samples easier
- SOFT braking function for slow acceleration and braking. Optimized for cell separation using gradient centrifugation
- The At set rpm function starts the timer when the selected speed has been reached; for reproducible centrifugation
- Key lock prevents unintentional adjustments
- Stainless steel rotor chamber is rust-proof and easy to clean
- Electronic imbalance detection for maximum safety

Product description

Centrifuge 5702/5702 R/5702 RH
English (EN)

Special features of Centrifuge 5702 R and Centrifuge 5702 RH

- Temperature settings from -9 °C to 40°C
- FastTemp function for fast precooling
- Continuous cooling maintains the set temperature of the Centrifuge 5702 R even when the lid is closed
- ECO switch-off function is activated after 8 hours without any operation to reduce energy consumption and to extend the life of the compressor
- Two program keys for storing routine runs
- Active heating ensures high temperature accuracy during the entire centrifugation (Centrifuge 5702 RH only)

3.4 Name plate

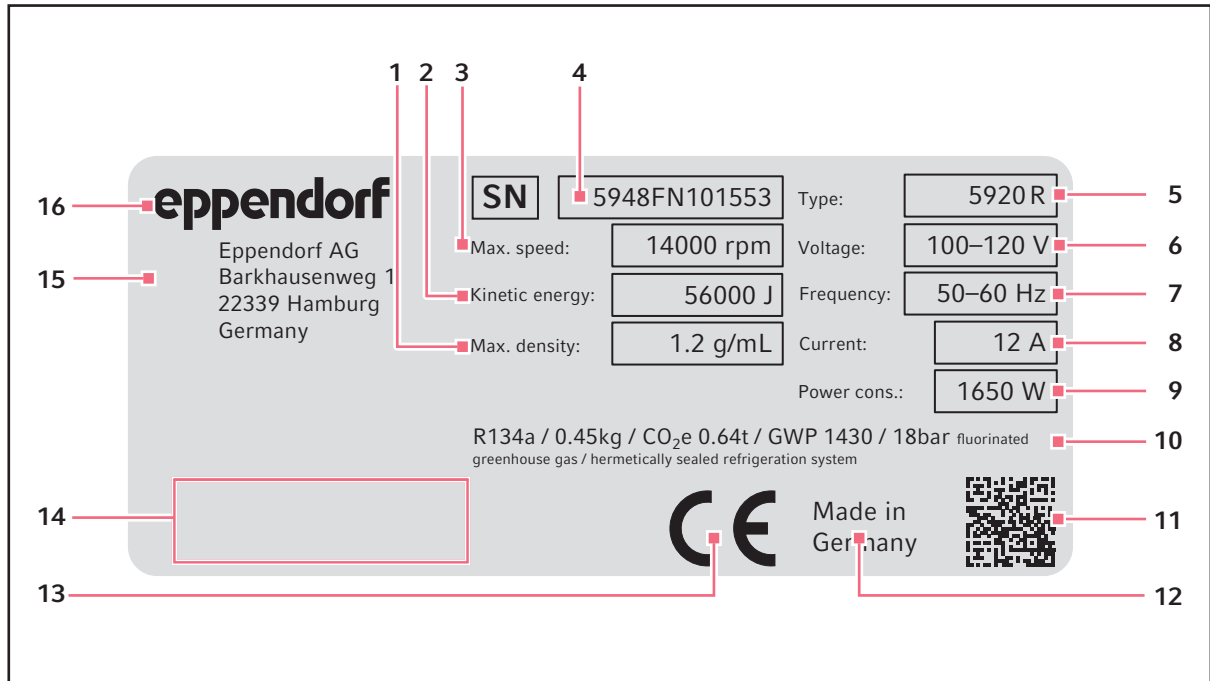









Fig. 3-3: Eppendorf AG device identification (example)

- | | |
|---|--|
| 1 Maximum density of the material for centrifuging | 9 Power consumption |
| 2 Maximum kinetic energy | 10 Information on the refrigerant (refrigerated centrifuges only) |
| 3 Maximum speed | 11 Data matrix code for serial number |
| 4 Serial number | 12 Designation of origin |
| 5 Product name | 13 CE marking |
| 6 Permitted voltage | 14 Certification marks and symbols (device-specific) |
| 7 Permitted frequency | 15 Address of manufacturer |
| 8 Current consumption | 16 Manufacturer |

Product description

Centrifuge 5702/5702 R/5702 RH
English (EN)

Tab. 3-1: Certification marks and symbols (device-specific)

Symbol/Approval mark	Meaning
	Serial number
	Manufacturer
	In vitro diagnostic device (Directive 98/79/EC), European Community
	Symbol for waste electrical and electronic equipment (WEEE) according to EU Directive 2012/19/EU, European Community
	UL mark: declaration of conformity, USA
	Conformity mark for electromagnetic compatibility according to the Federal Communications Commission, USA
	"China RoHS" conformity mark (Requirements for Concentration Limits for Certain Hazardous Substances in Electronic Information Products SJ/T 11363-2006), People's Republic of China

4 Installation

4.1 Selecting the location



NOTICE! If an error occurs, the objects in the immediate proximity of the device will be damaged.

- ▶ In accordance with the recommendations of EN 61010-2-020, leave a safety clearance of **30 cm** around the device during operation.
- ▶ Please remove all materials and objects from this area.



NOTICE! Damage from overheating.

- ▶ Do not place the device near heat sources (e.g., heating, drying cabinet).
- ▶ Do not expose the device to direct sunlight.
- ▶ Ensure unobstructed air circulation. Maintain a clearance of at least 30 cm (11.81 in) around all ventilation slits.



NOTICE! Radio interference.

This device is a category A product in accordance with EN 55011. There may be disturbance to radio reception in residential areas.

- ▶ Ensure that appropriate preventive measures are taken.



The mains/power switch and cutting unit of the mains/power line must be easily accessible during operation (e.g, residual current circuit breaker).

Select the location for the device according to the following criteria:

- Mains/power connection in accordance with the name plate.
- Minimum distance to other devices and walls: 30 cm (11.81 in).
- A resonance-free bench with a horizontal and even work surface which is designed to support the weight of the device.
- The location has good ventilation.
- The location is protected against direct sunlight.

4.2 Preparing installation



CAUTION! Risk of injury when lifting and carrying heavy loads

The device is heavy. Lifting and carrying the device can lead to back injuries.

- ▶ Only lift and transport the device with a sufficient number of helpers.
- ▶ Use a transport aid for transporting the device.



The device may only be stored and transported in its original packing.

- ▶ Retain the original packing, transport straps, packing material and transport securing devices.
- ▶ Do not cut up the transport straps.

Unpacking the centrifuge

1. Open the transport packing.
2. **Centrifuge 5702:** Remove the covering cardboard.
3. Take the accessories out of the packing.
4. Use the transport straps to lift the centrifuge out of the packing.
5. Place the device on a suitable work surface.
6. Remove the transport straps from the centrifuge.
7. There is a transport securing device attached to the front and the rear panel of the centrifuge. Remove the transport securing devices.
8. Remove the plastic sleeve.
9. **Centrifuge 5702:** The transport securing device for the motor is located underneath the centrifuge. Lift the centrifuge on one side and remove the transport securing device.
10. **Centrifuge 5702 R, Centrifuge 5702 RH:** Insert the condensation water tray.

4.3 Installing the instrument



WARNING! Risk from incorrect supply voltage

- ▶ Only connect the device to voltage sources which correspond to the electrical requirements on the name plate.
- ▶ Only use sockets with a protective earth (PE) conductor and suitable mains/power cord.



NOTICE! Damage to electronic components due to condensation.

Condensate can form in the device after it has been moved from a cool environment to a warmer environment.

- ▶ After installing the device, wait for at least 3 h. Only then connect the device to the mains/power line.



NOTICE! Centrifuge 5702 R, Centrifuge 5702 RH: Compressor damage after improper transport.

- ▶ After installation, wait 4 hours before switching on the centrifuge.
-

Prerequisites

- The device has been prepared in accordance with the operating manual.
 - The device has adapted to the ambient temperature (waiting time 3 h).
 - The compressor is ready for operation (waiting time 4 h).
1. Connect the mains/power cord of the centrifuge to the mains/power supply.
 2. Switch on the centrifuge using the mains/power switch.
 - The **standby** key lights up green.
 - The display is active.
 3. Open the centrifuge lid using the **open** key.

Installation

Centrifuge 5702/5702 R/5702 RH
English (EN)

5 Operation

5.1 Operating controls

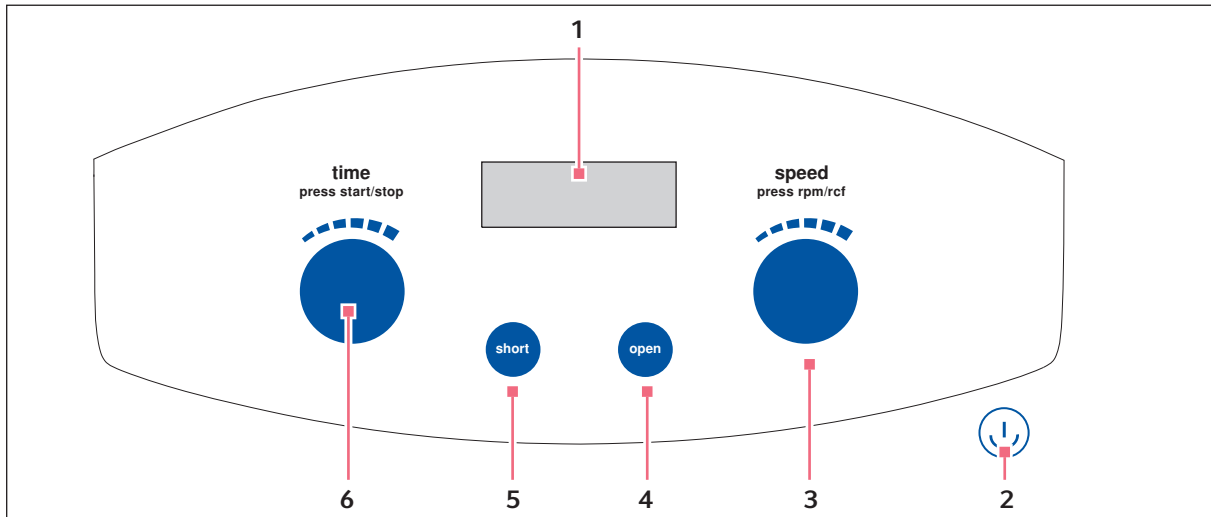



Fig. 5-1: Operating controls Centrifuge 5702

- | | |
|--|---|
| <p>1 Display</p> <p>2 Standby  key
Activate/deactivate standby mode
Key lights up green: Centrifuge is ready for operation
The key lights up red: Standby mode active</p> <p>3 Rotary knob speed
Turn the knob: Set the speed of centrifugation.
Press knob briefly: Switch display of centrifugation speed (rpm or rcf)</p> | <p>4 open key
Release the lid.</p> <p>5 short key
Short run centrifugation</p> <p>6 Rotary knob time
Turn the knob: Set the centrifugation time.
Press the knob: Start or stop centrifugation.</p> |
|--|---|

Operation

Centrifuge 5702/5702 R/5702 RH
English (EN)

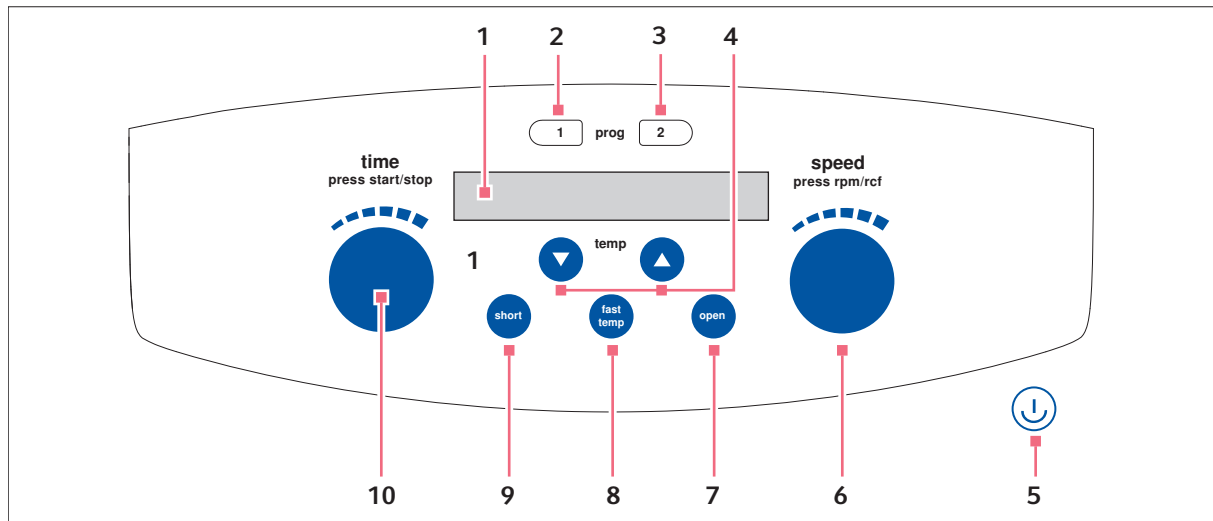



Fig. 5-2: Operating controls Centrifuge 5702 R, Centrifuge 5702 RH

- | | |
|--|--|
| <p>1 Display</p> <p>2 prog 1 key
Press the key briefly: Load program 1.
Press the key for > 2 s: Save current parameters.</p> <p>3 prog 2 key
Press the key briefly: Load program 2.
Press the key for > 2 s: Save current parameters.</p> <p>4 Arrow keys temp
Set the temperature.
Keep the arrow key pressed: Quick setting</p> <p>5 Standby  key
Activate/deactivate standby mode
Key lights up green: Centrifuge is ready for operation
The key lights up red: Standby mode is active</p> | <p>6 Rotary knob speed
Turn the knob: Set the speed of centrifugation.
Press the knob: Switch display of centrifugation speed (rpm or rcf)</p> <p>7 open key
Release the lid.</p> <p>8 fast temp key
Start a temperature control run FastTemp.</p> <p>9 short key
Short run centrifugation</p> <p>10 Rotary knob time
Turn the knob: Set the centrifugation time.
Press the knob: Starting and stopping centrifugation.</p> |
|--|--|

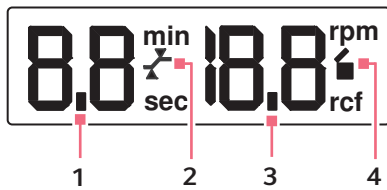







Fig. 5-3: Display Centrifuge 5702

- | | |
|---|---|
| <p>1 Centrifugation time [min, s]
Actual value</p> <p>2 Function At set rpm
 : time counting starts when 95% of the specified g-force [rcf] or speed [rpm] has been reached.
 : time counting begins immediately.</p> | <p>3 Rotational speed [rpm] or g-force [rcf]
Actual value</p> <p>4 Status of the centrifuge
 : The centrifuge lid has been released.
 : The centrifuge lid is locked.
  (Flashes): Centrifugation in progress.</p> |
|---|---|

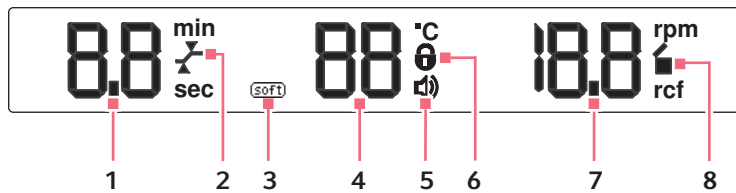











Fig. 5-4: Display Centrifuge 5702 R, Centrifuge 5702 RH

- | | |
|---|--|
| <p>1 Centrifugation time [min] or [s]
Actual value</p> <p>2 Function At set rpm
 : time counting starts when 95% of the specified g-force [rcf] or speed [rpm] has been reached.
 : time counting begins immediately.</p> <p>3 Soft ramp
 : Rotor accelerates and brakes slowly.
 No symbol: Rotor accelerates and brakes rapidly.</p> <p>4 Temperature in the rotor chamber [°C]
Actual value</p> | <p>5 Key lock
 : The key lock is activated. Parameters cannot be changed.
 : The key lock is not activated.</p> <p>6 Speaker
 : The speaker is switched on.</p> <p>7 g-force [rcf] or rotational speed [rpm]
Actual value</p> <p>8 Status of the centrifuge
 : The centrifuge lid has been released.
 : The centrifuge lid is locked.
  (Flashes): Centrifugation in progress.</p> |
|---|--|



Centrifuge 5702 R only: When setting the soft ramp the  symbol only appears on the display from serial number 03556.
For devices with serial numbers < 03556 (see *Setting a soft ramp* on p. 36).

5.2 Switching on the centrifuge

Prerequisites

- The device has been installed in accordance with the operating manual.

1. Switch the centrifuge on using the mains/power switch.
2. Press the **Standby** key, if required.
The display shows the parameters of the last run.
3. Press the **open** key to open the closed centrifuge lid.

5.3 Replacing the rotor



NOTICE! If handled incorrectly, the rotor may fall.

The swing-bucket rotor may fall if the buckets are used as handles.

- ▶ Remove the buckets before inserting and/or removing a swing-bucket rotor.
- ▶ Always use both hands to carry the rotor cross.



NOTICE! Material damage due to improper rotor insertion.

The motor shaft or bearing may get damaged if the rotor falls into the motor shaft guides in an uncontrolled manner during insertion.

- ▶ Hold the rotor with both hands.
- ▶ Guide the rotor onto the motor shaft.

5.3.1 Inserting the rotor

1. Align the peg of the motor shaft.
2. Place the rotor vertically onto the motor shaft from the top.
The arrows on the rotor show the position of the groove. The pegs of the motor shaft must fit into the groove of the rotor.
If required, lift the rotor and replace it onto the motor shaft.
3. Insert the rotor key supplied into the rotor nut.
4. Turn the rotor key **clockwise** until the rotor nut is firmly tightened.

5.3.2 Removing the rotor

1. Turn the rotor nut **counterclockwise** using the rotor key supplied.
2. Remove rotor by lifting it vertically.

5.4 Loading a fixed-angle rotor



CAUTION! Risk of injury due to asymmetric loading of the rotor.

- ▶ Load rotors symmetrically with identical tubes.
- ▶ Only load adapters with suitable tubes.
- ▶ Always use the same type of tubes (weight, material/density and volume).
- ▶ Check symmetric loading by balancing the adapters and tubes used with scales.

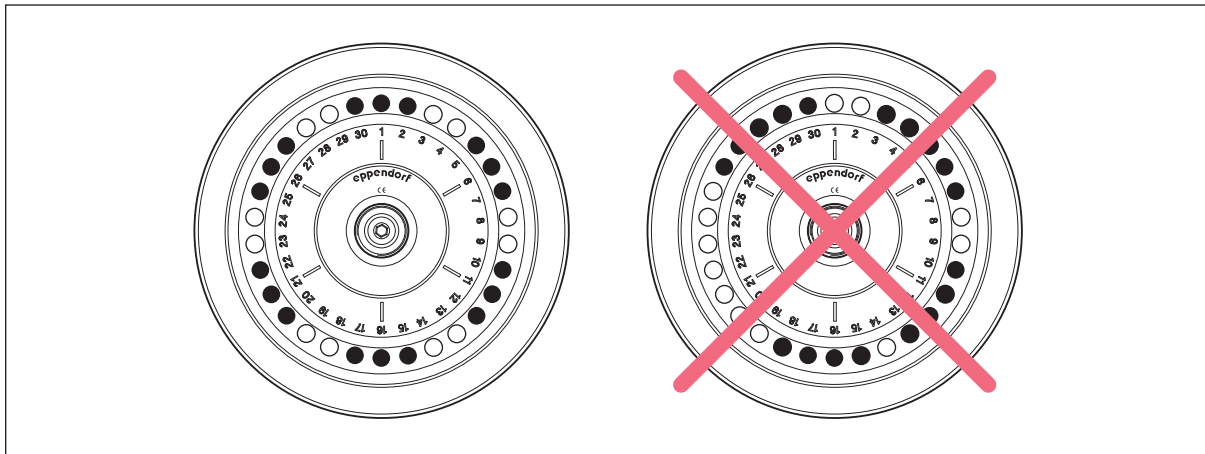

Fig. 5-5: Symmetrical loading of a fixed-angle rotor

1. Check maximum load (adapter, vessel, and contents) for each rotor bore.
2. Load rotors and adapters only with the tubes intended for them.
3. To ensure symmetrical loading, insert sets of two tubes in opposite bores.

Tubes located opposite each other must be of the same type and contain the same filling quantity.

To minimize weight differences between filled sample tubes, we recommend taring with a balance. This will reduce wear of the drive and operating noise.

5.5 Loading a swing-bucket rotor



CAUTION! Risk of injury due to asymmetric loading of the rotor.

- ▶ Load rotors symmetrically with identical tubes or plates and buckets.
- ▶ Always load all positions of a swing-bucket rotor with buckets.
- ▶ Only load adapters with suitable tubes or plates.
- ▶ Always use tubes or plates of the same type (weight, material/density and volume).
- ▶ Check that loading is symmetrical by balancing the adapters and tubes or plates used with scales.

5.5.1 Inserting the bucket in the swing-bucket rotor

Prerequisites

- The combination of rotor, bucket, adapter and vessel has been approved by Eppendorf.
- Buckets that are located opposite each other belong to the same weight class. The weight class is engraved in the sides of the groove: e.g., 68.
- The bucket grooves are clean and have been lubricated slightly with pivot grease.

1. Check the maximum load (adapter, vessel, and contents) for each bucket. Check the length of the vessels.

The weight that a fully loaded bucket must not exceed is indicated on each rotor.

2. Insert the buckets into the rotor. Load the rotor symmetrically

All rotor positions must be occupied with buckets.

Only place buckets opposite each other that have the same weight class.

3. Check that all carriers are hanging properly and can swing freely.



- ▶ Carry out an imbalance calibration if you are using tubes or plates for the first time.

5.5.2 Performing an imbalance calibration

You can perform a manual imbalance calibration to check how the buckets are swinging. The speed of centrifugation must be a maximum of 1000 rpm.

Perform the imbalance calibration when the following prerequisites have been met:

- You are using the tubes for the first time.
- You are using tubes with a length of > 100 mm.

1. Bucket loaded with tubes.
2. Equip the rotor with buckets.
3. Accelerate the rotor manually until the buckets swing out at 90°.

If the following results are obtained the imbalance calibration was successful:

- The buckets swing freely.
- The tubes do not touch the rotor cross.

5.5.3 Loading the buckets symmetrically



NOTICE! Material damage due to incomplete loading of the swing-bucket rotor.
Incomplete loading of the swing-bucket rotor reduces the rotor's service life.

- ▶ Always load all positions of a swing-bucket rotor with buckets.

5.5.3.1 Equipping buckets with vessels

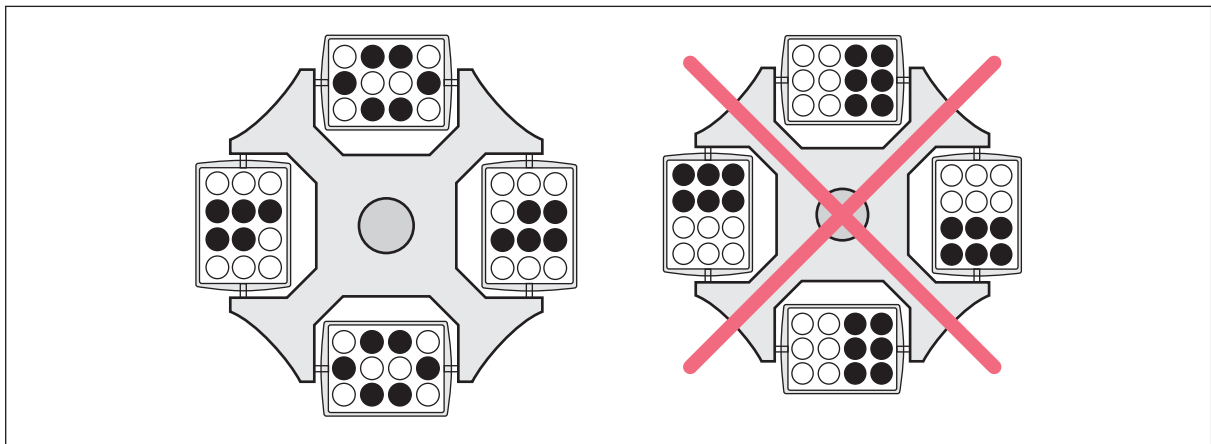

Fig. 5-6: Correct and incorrect loading of the buckets

The equipping shown on the right-hand side is incorrect as it places an uneven load on the pegs of the rotor.

- ▶ To reduce vibrations and noise, load all buckets of the swing-buckets rotor equally.

5.5.3.2 Closing round buckets with a cap

**CAUTION! Risk of injury due to chemically damaged rotor lids or caps.**

Transparent rotor lids or caps made from PC, PP or PEI may lose their strength under the impact of organic solvents (e.g. phenol, chloroform).

- ▶ If rotor lids or caps have come into contact with organic solvents, they should be cleaned immediately.
- ▶ Check the rotor lids and caps regularly for any damages and cracks.
- ▶ Replace any rotor lids or caps which show cracks or milky stains immediately.

**NOTICE! Damage to the cap from organic solvents.**

The cap is made from polycarbonate. Polycarbonate is not resistant to phenol and chloroform. Phenol and chloroform vapors damage the cap and reduce the aerosol tightness.

- ▶ If you are using the cap do not centrifuge any substances which contain phenol or chloroform.

You can close the round bucket using an aerosol-tight cap.

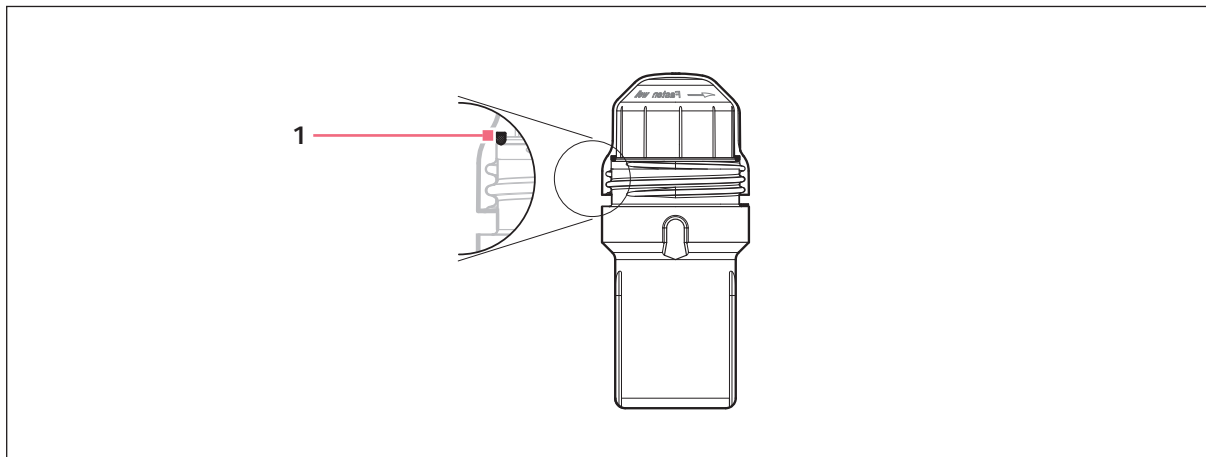

Fig. 5-7: Round bucket with a cap

1 Sealing ring

1. Check the sealing ring in the cap.
The sealing ring is not damaged and is seated evenly in the groove.
2. Place the cap on the bucket and screw it tight.

5.6 Closing the centrifuge lid



WARNING! Risk of injury when opening or closing the centrifuge lid.

There is a risk of crushing your fingers when opening or closing the centrifuge lid.

- ▶ When opening or closing the centrifuge lid, do not reach between the lid and device or into the latching mechanism of the lid.
- ▶ Always open the centrifuge lid completely to prevent it from falling.

1. Check that the rotor is attached correctly.
2. Press the centrifuge lid down until it is gripped by the lid latch. The lid will be closed automatically.
 - The  symbol appears on the display.

5.7 Aerosol-tight centrifugation

Aerosol-tight caps are available for the round buckets of rotor A-4-38.



WARNING! Damage to health due to leaking cap.

The aerosol tightness of caps is reduced by autoclaving, mechanical strain and contamination by chemicals.

- ▶ Check the cap and the gasket before each use. Only use caps work with undamaged and clean gaskets.
- ▶ Replace the caps after 50 autoclaving cycles.
- ▶ Store the cap separately. Do not screw the cap onto the bucket.



The aerosol tightness of the cap has been tested and certified in accordance with Annex AA of IEC 1010-2-020.

5.7.1 Aerosol-tight centrifugation in a swing-bucket rotor

- ▶ For aerosol-tight centrifugation in a swing-bucket rotor, use buckets with aerosol-tight caps (see *Closing round buckets with a cap* on p. 32).

5.8 Centrifugation

Prerequisites:

- The centrifuge is switched on.
- The rotor has been inserted and attached correctly.
- The rotor has been loaded correctly.
- Buckets can freely swing out.
- The centrifuge lid is closed.



WARNING! Risk of injury from improperly attached rotors and rotor lids.

- ▶ Only centrifuge with rotor and rotor lid firmly tightened.
- ▶ If there are any unusual noises when the centrifuge is started up, the rotor or rotor lid may not be properly attached. Immediately press the start/stop key to stop centrifuging.

5.8.1 Centrifugation with time setting

5.8.1.1 Setting the centrifugation parameters

Setting the centrifugation parameters

1. Use the rotary knob **time** to set the centrifugation time.
2. Centrifuge 5702 R, Centrifuge 5702 RH: Use the **temp** arrow keys to set the temperature.
3. Use the rotary knob **speed** to set the speed of centrifugation.

Starting the centrifugation run

4. Press the rotary knob **time** to start the centrifugation run.

Display during centrifugation

- ■ blinks in the display when the rotor is running.
- Remaining run time in minutes. The last minute is counted down in seconds.
- Centrifuge 5702 R, Centrifuge 5702 RH: Actual temperature in the rotor chamber
- Current *g*-force (rcf) and/or rotational speed (rpm).

Modifying parameters during the cycle

5. To modify the following centrifugation parameters during the run, briefly press the **short** key. The display flashes.



During the run you can change the following parameters:

- Centrifugation time
The shortest new run time that can be set must be 2 min above the elapsed time.
- Centrifuge 5702 R, Centrifuge 5702 RH: Temperature
- Centrifugation speed
During the run you can use rotary knob **speed** to switch between the display of the *g*-force and the rotational speed.
The modified centrifugation parameters are adopted after 5 s.

5.8.1.2 End of centrifugation

- ▶ Press the rotary knob **time** to abort centrifugation.
 - The centrifuge stops automatically when the set time has elapsed.
 - During the braking process, the elapsed run time flashes on the display.
 - The signal sounds when the rotor is stopped.
 - To maintain the temperature in the rotor chamber, the centrifuge lid of the Centrifuge 5702 R and Centrifuge 5702 RH remains closed. Press the **open** key to open the lid.
 - The centrifuge lid of the Centrifuge 5702 opens automatically.

5.8.2 Centrifuging in continuous operation

Setting up continuous operation

1. To operate the centrifuge for an unlimited period, use rotary knob **time** to select the setting ∞ (before 0.5 min and after 99 min).
The ∞ symbol appears on the display.
2. Centrifuge 5702 R, Centrifuge 5702 RH: Use the **temp** arrow keys to set the temperature.
3. Use the rotary knob **speed** to set the speed of centrifugation.

Starting a continuous run

4. Press the rotary knob **time** to start the centrifugation run.

Ending a continuous run

5. Press the rotary knob **time** to end the centrifugation run.
 - During the braking process, the centrifugation time flashes on the display.
 - The signal sounds when the rotor is stopped.
6. To maintain the temperature in the rotor chamber, the centrifuge lid of the Centrifuge 5702 R and Centrifuge 5702 RH remains closed. Press the **open** key to open the lid.
The centrifuge lid of the Centrifuge 5702 opens automatically.

5.8.3 Short run centrifugation

The short spin centrifugation runs as long as the **short** key is pressed. The centrifugation is performed with the maximum rotational speed of the rotor.

1. Centrifuge 5702 R, Centrifuge 5702 RH: Use the **temp** arrow keys to set the temperature.
2. Press and hold the **short** key to start short run centrifugation.
3. Release the **short** key to end short-spin centrifugation.
During the braking process, the centrifugation time flashes on the display.
4. To maintain the temperature in the rotor chamber, the centrifuge lid of the Centrifuge 5702 R and Centrifuge 5702 RH remains closed. Press the **open** key to open the lid.
The centrifuge lid of the Centrifuge 5702 opens automatically.

Operation

Centrifuge 5702/5702 R/5702 RH
English (EN)

5.8.4 Setting a soft ramp



There are 2 settings for soft ramps available for the Centrifuge 5702/5702 R/5702 RH. Use the slow soft ramps for sensitive applications.

Prerequisites

- The centrifuge lid is open.

1. To check which soft ramps are set, briefly press the **short** key several times.

The display shows the soft ramps that have been set.

Soft ramps	Centrifuge 5702	Centrifuge 5702 R Serial number < 03556	Centrifuge 5702 R Serial number > 03556	Centrifuge 5702 RH
Fast	<i>br on</i>	<i>br on</i>	No symbol	No symbol
Slow	<i>br OF</i>	<i>br OF</i>		



2. Press the **short** key for > 5 s.

The setting for the soft ramps is modified. The display shows the current status.

3. To modify the setting for the soft ramps again, press the **short** key for > 5 s.

5.8.5 Setting the beginning of time counting (At set rpm function)

You can specify when time counting should start.

Beginning of time counting	Display
Time counting starts immediately (delivery condition)	
Time counting starts when 95 % of the g-force and/or rotational speed has been reached.	

1. Press rotary knob **time** > 2 s.

The start of time counting is changed. The display shows the current status.

2. To change the start of time counting again, press rotary knob **time** > 2 s.

5.8.6 Calculating the speed of centrifugation

The g -force that is shown on the display is standardized for rotor A-4-38 with conical tubes 15 mL without an adapter. If different rotors and adapters are used, different g -forces are achieved.



Maximum g -force and maximum radius for the corresponding rotors and adapters (see *Rotors, tubes and adapters* on p. 65).

To calculate the g -force, use the following formula in accordance with DIN 58970:

- $rcf = 1.118 \cdot 10^{-5} \cdot n^2 \cdot r_{\max}$
 - rcf: g -force
 - n: Rotational speed in rpm
 - r_{\max} : maximum centrifugation radius in cm

Example 1

- The adapter for HPLC vessels in the rotor F-45-18-17-Cryo has a maximum radius of 8.3 cm.
- At a speed of 6142 rpm, a maximum g -force of $3\,500 \times g$ is achieved.

Example 2

- The adapter 100 mL has a maximum radius of 13.5 cm.
- At 4,000 rpm a maximum g -force of $2,415 \times g$ is achieved.

5.9 Centrifuge 5702 R, Centrifuge 5702 RH: Heating and cooling

The rotor chamber of the Centrifuge 5702 R can be cooled. The rotor chamber of the Centrifuge 5702 RH can be heated and cooled.



The temperature that can actually be reached depends on the rotor and the set rotational speed.

If the rotor stops (continuous cooling), cooling is slower than during centrifugation or a temperature control run.



At high ambient temperatures the fan may be audible briefly until the set temperature is reached. A running fan indicates a high cooling performance.

At ambient temperatures $< 18^\circ\text{C}$ a warm-up period of approx. 1 h is required for it to function properly.

5.9.1 Setting the temperature

Prerequisites

- The centrifuge is switched on.
- The centrifuge lid is closed.

1. Use the **temp** arrow keys to set the set temperature.
2. Set the centrifugation time and centrifugation speed.
3. Press the rotary knob **time** to start centrifugation.

The temperature can be changed during centrifugation.

Operation

Centrifuge 5702/5702 R/5702 RH
English (EN)

5.9.2 Temperature display

Temperature display if the rotor stops:	The display switches between the set temperature (long) and the actual temperature (short).
Temperature display during centrifugation:	Actual temperature

5.9.3 Temperature monitoring

Once the set temperature has been reached, the centrifuge reacts to temperature deviations during centrifugation as follows:

Deviation from the set temperature $> \pm 3 \text{ }^\circ\text{C}$	Temperature display flashes
Deviation from the set temperature $> \pm 5 \text{ }^\circ\text{C}$	The display shows <i>Er 18</i> . Centrifugation is stopped automatically.

The temperature can be changed during centrifugation.

5.9.4 Temperature control run FastTemp

Reasons for a temperature control run

- Rotor chamber, rotor and adapter should reach the set temperature quickly.
- To perform a run with the exact temperature, start a short temperature control run immediately before centrifugation. This prevents exceeding the temperature in the rotor chamber, e.g. following a long service life.
- If the centrifuge has been used with continuous cooling over a longer period of time or with continuous cooling at lower temperatures, start a brief temperature control run before inserting the samples. The temperature control run prevents the samples from freezing.

5.9.4.1 Starting a temperature control run

With the FastTemp function, you can start a temperature control run immediately without samples, at rotor-specific or temperature-specific speeds. This will quickly bring the rotor chamber, including rotor and adapter, up to the set temperature.

Prerequisites

- The centrifuge is switched on.
- Rotor, rotor lid and adapter have been mounted correctly.
- The centrifuge lid is closed.

1. Set the speed of centrifugation for the subsequent run.
2. Use the arrow keys to set the set temperature.
3. Press the **fast temp** key.

The display shows the following information:

- *FA*
- Actual temperature in the rotor chamber
- Rotational speed

The temperature control run FastTemp stops automatically when the set temperature has been reached. When the speaker is activated, an alarm will sound periodically.

4. Press the rotary knob **time** to end the temperature control run FastTemp early.



- The centrifuge only stops the temperature control run FastTemp once the rotor has reached the set temperature. Therefore, there may be a delay between the display of the set temperature that has been reached and the automatic end of the temperature control run.
- The set temperature can be changed during the temperature control run, using the **temp** arrow keys. The duration and the speed of the temperature control run are adjusted automatically.

5.9.4.2 Temperature control run with aerosol-tight caps

If you perform a temperature control run and close the buckets with aerosol-tight caps, a negative pressure will be generated in the buckets. After the temperature control run the caps cannot be removed.

1. Do not use aerosol-tight caps for temperature control runs.
2. Temper bucket and adapters without aerosol-tight caps.

5.9.5 Continuous cooling

Continuous cooling maintains the rotor chamber at the set temperature if the rotor stops.

- During continuous cooling the display shows the set temperature.
- To prevent the rotor chamber from freezing or condensation from forming, the temperature does not go below 4 °C irrespective of the set temperature.
- If the rotor stops, temperature control is slower than during centrifugation or a temperature control run.
- Continuous cooling ends after 8 h.

Prerequisites

- The centrifuge is switched on.
- The centrifuge lid is closed.
- The set temperature is lower than the ambient temperature.

Continuous cooling starts automatically.

Operation

Centrifuge 5702/5702 R/5702 RH
English (EN)

5.9.6 Centrifuge 5702 RH: Temperature profiles

The Centrifuge 5702 RH has a regulated heating and cooling system. This enables the exact tempering of delicate samples.

For each rotor a special temperature profile is set up in the software. The temperature profile determines the speed at which the rotor performs the temperature control run FastTemp. The objective is to temper the rotor chamber and the rotor to the set temperature as quickly as possible. The temperature must be maintained with low tolerances.

Prerequisites

- The centrifuge lid is open.

1. Press the **fast temp** key.

The last temperature profile that was selected is displayed.

Display	Rotor
<i>ro F 35</i>	Rotor F-35-30-17
<i>ro F 24</i>	Rotor F-45-24-11
<i>ro F 18</i>	Rotor F-45-18-17-Cryo
<i>ro A4 rE</i>	Rotor A-4-38 with rectangular buckets
<i>ro A4 ro</i>	Rotor A-4-38 with round buckets
<i>ro A8</i>	Rotor A-8-17
<i>ro AL L</i>	Temperature profile for all rotors

2. Use the arrow keys to select the temperature profile for the rotor that is used.

The selected temperature profile is adopted after 5 s. The display shows the standard values again.

5.10 Switching off the centrifuge

1. Open the centrifuge lid.

The residual moisture can evaporate. The pressure on the springs is released.

2. Remove the aerosol-tight caps from the buckets.

Aerosol-tight accessories may not be stored when they are connected.



3. Switch off the centrifuge using the mains/power switch.

6 Device settings



6.1 Changing the operating state

The centrifuge has 2 operating states, the ready state and standby mode. You can actively change between the two operating states.

The **Standby**  key shows the operating state of the device.





- The device is ready for operation: The **Standby**  key lights up green.
- The device is in standby mode: The **Standby**  key lights up red.

Prerequisites

- The centrifuge is not performing a run.
- ▶ Press the **Standby**  key to change the operating state.
The operating state changes. The **Standby**  key changes color.

6.2 Key lock

The display shows if the key lock is activated.

	Centrifuge 5702	Centrifuge 5702 R	Centrifuge 5702 RH
Key lock is activated	<i>Lo on</i>		
Key lock is deactivated	<i>Lo OF</i>		

When the key lock is activated, the following centrifugation parameters cannot be changed:

- Centrifugation time
- Centrifuge 5702 R, Centrifuge 5702 RH: temperature
- *g*-force and/or rotational speed
- Soft ramps
- Status of the At set rpm function

The following settings can still be changed when the key lock is activated:

- Starting and stopping centrifugation. Press the rotary knob **time** for this.
- Setting the unit for the speed of centrifugation [rpm/ rcf]. Press the rotary knob **speed** for this.
- Activating and deactivating the speaker. Press the **open** key > 2s.

Activating the key lock

Prerequisites

- The centrifuge lid is open.
- ▶ Press the **short** key and the **open** key simultaneously for > 5 s.
The centrifugation parameters cannot be changed.

Deactivating the key lock

Prerequisites

- The centrifuge lid is open.
- ▶ Press the **short** key and the **open** key simultaneously for > 5 s.
The centrifugation parameters can be changed.

Device settings

Centrifuge 5702/5702 R/5702 RH
English (EN)

6.2.1 Centrifuge 5702 R, Centrifuge 5702 RH: Securing the program against any changes

1. Open the program using the **prog 1** or the **prog 2** key.
2. Activate the key lock by pressing the **short** key and the **open** key simultaneously for > 5 s.
The program cannot be changed.

6.2.2 Centrifuge 5702: Displaying the key lock status



On the Centrifuge 5702 R and the Centrifuge 5702 RH the status of the key lock is shown on the display.

Prerequisites

- The centrifuge lid is open.
- ▶ Briefly press the **short** key and the **open** key simultaneously.
The display shows the status of the key lock.

6.3 Speakers

The display shows if the speakers are switched on.

	Centrifuge 5702	Centrifuge 5702 R	Centrifuge 5702 RH
Speakers switched on	<i>b on</i>		
Speakers switched off	<i>b OF</i>	no symbol	no symbol

Switching on the speakers

Prerequisites

- The centrifuge lid is open.
- ▶ Press the **open** key for > 2 s.
The speakers are switched on.

Switching off the speakers

Prerequisites

- The centrifuge lid is open.
- ▶ Press the **open** key for > 2 s.

6.3.1 Display the status of the speakers

This function is only available for the Centrifuge 5702. On the Centrifuge 5702 R and the Centrifuge 5702 RH the status of the speakers is shown on the display.

Prerequisites

- The centrifuge lid is open.
- ▶ Press the **open** key briefly.
The display shows the status of the speakers.

7 Programs

You can store 2 programs each on the Centrifuge 5702 R and on the Centrifuge 5702 RH.

You can set the following parameters for each program:

- Centrifugation time
- Temperature
- Centrifugation speed
- Start of time measurement (function At set rpm)
- Settings for the soft ramp

7.1 Creating and storing a program

You can store two programs on the device

Prerequisites

- Rotor stop.
1. Use the rotary knob **time** to set the centrifugation time.
 2. Use the **temp** arrow keys to set the temperature.
 3. Use the rotary knob **speed** to set the speed of centrifugation.
 4. Set the start of time counting (function At set rpm). Press rotary knob **time** > 2 s to do this.
 5. Press the **short** key > 5 s to set the soft ramp.
 6. Select the program slot. Press the **prog 1** key or the **prog 2** key > 2 s.
 - A signal sounds.
 - The program key does not flash any more. The program key lights up blue.
 - The parameters of the program are saved.

7.2 Saving the current settings as a program

You can save the current settings as a program.

Prerequisites

- Rotor stop.
- ▶ Press the **prog 1** key or the **prog 2** key > 2 s.
- A signal sounds.
 - The program key lights up blue.
 - The parameters of the program are saved.

Programs

Centrifuge 5702/5702 R/5702 RH
English (EN)

7.3 Calling up a program

You can call up stored programs.

Prerequisites

- Rotor stop.
- ▶ Press the **prog 1** key or **prog 2** key to call up a program.
 - The program key lights up blue.
 - The display shows the parameters of the program.

7.4 Editing programs

You can overwrite stored programs.



If a program is loaded, the parameters cannot be changed. The following text appears in the display - *Pr 1* for program 1 or *Pr 2* for program 2.

Prerequisites

- The program has been created and stored.
 - The program has been called up. The program key **prog 1** or **prog 2** lights up blue.
1. Press the key again on which the program has been stored.

The program key does not light up any more.
The display shows the centrifugation parameters.
The centrifugation parameters can be adjusted.
 2. Change the centrifugation parameters.
 3. Store the program on the old program slot. Press the **prog 1** key or **prog 2** > 2 s to do this.
 - A signal sounds.
 - The program key does not flash any more. The program key lights up in blue.
 - The parameters of the program are saved.

7.5 Deleting programs

Programs 1 and 2 cannot be deleted. The programs can be overwritten.

7.6 Exiting the program

Prerequisites

- The program has been called up. The program key **prog 1** or **prog 2** lights up blue.
- ▶ Press the **prog 1** key or the **prog 2** key to exit the program.
 - The program key does not light up any more.
 - The display shows the centrifugation parameters.
 - The centrifugation parameters can be adjusted.

8 Maintenance

8.1 Service

We recommend to have the centrifuge and the associated rotors checked by Technical Service during a service at least every 12 months. Please note the country-specific regulations.

8.2 Prepare cleaning/disinfection

- ▶ Clean all accessible surfaces of the device and the accessories at least weekly and when contaminated.
- ▶ Clean the rotor regularly. This way the rotor is protected and the durability is prolonged.
- ▶ Furthermore, observe the notes on decontamination (see *Decontamination before shipment on p. 49*) when the device is sent to the authorized Technical Service for repairs.

The procedure described in the following chapter applies to the cleaning as well as to the disinfection or decontamination. The table below describes the steps required on top of this:

Cleaning	Disinfecting/decontamination
<ol style="list-style-type: none"> 1. Use a mild cleaning fluid to clean the accessible surfaces of the device and the accessories. 2. Carry out the cleaning as described in the following chapter. 	<ol style="list-style-type: none"> 1. Choose the disinfection method which corresponds to the legal regulations and guidelines in place for your range of application. For example, use alcohol (ethanol, isopropanol) or alcohol-based disinfectants. 2. Carry out the disinfection or decontamination as described in the following chapter. 3. Then clean the device and the accessories.



If you have any further questions regarding the cleaning and disinfection or decontamination or regarding the cleaning fluid to be used, contact the Eppendorf AG Application Support. The contact details are provided on the back of this manual.

8.3 Cleaning/disinfection

**DANGER! Electric shock as a result of penetration of liquid.**

- ▶ Switch off the device and disconnect the mains/power plug before starting cleaning or disinfection work.
 - ▶ Do not allow any liquids to penetrate the inside of the housing.
 - ▶ Do not spray clean/spray disinfect the housing.
 - ▶ Only plug the device back in if it is completely dry, both inside and outside.
-

**NOTICE! Damage from the use of aggressive chemicals.**

- ▶ Do not use any aggressive chemicals on the device or its accessories, such as strong and weak bases, strong acids, acetone, formaldehyde, halogenated hydrocarbons or phenol.
- ▶ If the device becomes contaminated with aggressive chemicals, clean it immediately using a mild cleaning agent.

**NOTICE! Corrosion due to aggressive cleaning agents and disinfectants.**

- ▶ Do not use corrosive cleaning agents, aggressive solvents or abrasive polishes.
- ▶ Do not incubate the accessories in aggressive cleaning agents or disinfectants for a longer period of time.

**NOTICE! Damage from UV and other high-energy radiation.**

- ▶ Do not use UV, beta, gamma, or any other high-energy radiation for disinfecting.
 - ▶ Avoid storage in areas with strong UV radiation
-

**Autoclaving**

Fixed-angle rotors, rotor lids and adapters can be autoclaved (121 °C, 20 min).

Rotor crosses of swing-bucket rotors cannot be autoclaved.

After a maximum of 50 autoclaving cycles, the aerosol-tight caps must be replaced.

8.3.1 Cleaning and disinfecting the device

Cleaning agents:

- Alcohol 70 % (ethanol, isopropanol)
- Mild, neutral cleaning agent
- Lint-free cloth

1. Open the lid.
2. Switch off the device and disconnect it from the voltage supply.
3. Remove the rotor.
4. Use a damp cloth and the cleaning agents to clean and disinfect all the accessible areas of the device, including the mains/power cord.
5. Wash the rubber seal in the rotor chamber thoroughly with water.
6. Let the rubber seal dry off.
7. Rub the rubber seal with glycerol or talcum powder. This will prevent the rubber seal from becoming brittle.

Other components of the device, such as the motor shaft and rotor cone, must not be lubricated.

8. Clean the motor shaft with a soft, dry, lint-free cloth.
9. Check the motor shaft for damage.
10. Check the device for corrosion and damage.
11. Leave the centrifuge lid open when the device is not in use.
12. Only connect the device to the mains/power supply when it is fully dry inside and out.

8.3.2 Disinfecting and cleaning the rotor

1. Inspect the rotor and accessories for damage and corrosion. Do not use any damaged rotors or accessories.
2. Clean and disinfect the rotors and accessories using the recommended cleaning agents.
3. Clean and disinfect the rotor bores using a bottle brush.
4. Rinse the rotors and accessories thoroughly with distilled water. Rinse the rotor bores of fixed-angle rotors particularly thoroughly.



Do not immerse the rotor in liquid as liquid can get trapped inside the cavities.

5. Place rotors and accessories on a towel to dry. Place the fixed-angle rotors with the rotor bores facing down so the bores can dry.
6. Clean the rotor cone with a soft, dry, lint-free cloth. Do not lubricate the rotor cone.
7. Inspect the rotor cone for damage.
8. Place the dry rotor onto the motor shaft.
9. Tighten the rotor nut firmly by turning it **clockwise** with the rotor key.
10. If required, equip the fixed-angle rotor with the cleaned adapters.
11. Equip the swing-bucket rotor with the cleaned buckets and adapters.

8.4 Additional care instructions for refrigerated centrifuges

- ▶ Empty and clean the condensation water tray regularly. Pull out the condensation water tray to the left underneath the device.
- ▶ Regularly free the rotor chamber from ice formations by thawing, by either leaving the centrifuge lid open or by performing a short temperature control run at approx. 30 °C.
- ▶ To take pressure off the gas spring(s), leave the centrifuge lid open if the centrifuge is not used for a longer period.
Residual moisture can escape.
- ▶ Leave the centrifuge lid open when not in use for a longer period.
Residual moisture can escape. The lid spring is relieved.
- ▶ Wipe up the condensation water in the rotor chamber. Use a soft, absorbent cloth for this.
- ▶ No later than every 6 months, remove any dust deposits from the ventilation slits of the centrifuge using a brush or swab. First switch off the device and remove the power plug.

8.5 Cleaning glass breakage

When using glass tubes there is a risk of glass breakage in the rotor chamber. The resulting glass splinters are swirled around in the rotor chamber during centrifugation and have a sandblasting effect on the rotor and accessories. The smallest glass particles become lodged in the rubber parts (e.g., the motor guide, the rotor chamber seal, and the rubber mats of adapters).



NOTICE! Glass breakage in the rotor chamber

Glass tubes in the rotor chamber may break if the *g*-force is too high. Broken glass can damage the rotor, accessories and samples.

- ▶ Please note the manufacturer's information on the recommended centrifugation parameters (load and speed).

Effects of glass breakage in the rotor chamber:

- Fine black metal abrasion in the rotor chamber (in metal rotor chambers)
- The surfaces of the rotor chamber and accessories are scratched.
- The chemical resistance of the rotor chamber is reduced.
- Contamination of samples
- Wear on rubber parts

How to proceed in case of glass breakage

1. Remove all splinters and glass powder from the rotor chamber and accessories.
2. Thoroughly clean the rotor and rotor chamber. Thoroughly clean the bores of the fixed-angle rotors, in particular.
3. If required, replace the rubber mats and adapters to prevent any further damage.
4. Regularly check the rotor bores for deposits and damage.

8.6 Replacing the fuses

The holder is located below the mains/power connection.

1. Switch off the device and isolate it from the mains/power supply.
2. Pull the fuse holder out of the device.
3. Replace the fuses.

8.7 Decontamination before shipment

If you are shipping the device to the authorized Technical Service for repairs or to your authorized dealer for disposal please note the following:



WARNING! Risk to health from contaminated device

1. Follow the instructions in the decontamination certificate. You can find it as a PDF file on our website (www.eppendorf.com/decontamination).
 2. Decontaminate all the parts you would like to dispatch.
 3. Include the fully completed decontamination certificate in the packing.
-

Maintenance

Centrifuge 5702/5702 R/5702 RH
English (EN)

9 Troubleshooting

If you cannot remedy an error with the recommended measures, please contact your local Eppendorf partner. The contact addresses can be found on the Internet at www.eppendorf.com.

9.1 General errors

Problem	Cause	Solution
No display.	No mains/power connection.	▶ Check the mains/power connection.
	Mains/power outage.	▶ Check the mains/power fuse of the device (see <i>Replacing the fuses on p. 49</i>). ▶ Check the mains/power fuse of the laboratory.
Lid of the device cannot be opened.	Rotor is still running.	▶ Wait for rotor to stop.
	Mains/power outage.	1. Check the mains/power fuse of the device (see <i>Replacing the fuses on p. 49</i>). 2. Check the mains/power fuse of the laboratory. 3. Activate the emergency lid release (see p. 55).
Device cannot be started.	Lid of the device is not closed.	▶ Close the lid of the device.
Device shakes when it starts up.	Rotor is asymmetrically loaded.	1. Stop the device and load symmetrically. 2. Restart the device.
Temperature display flashes. (only Centrifuge 5702 R, Centrifuge 5702 RH)	Temperature deviation from set value: ± 3 °C.	▶ Check the settings. ▶ Check unhindered air circulation through the air slots. ▶ Thaw ice or switch off device and allow it to cool down.
Standby key lights up red.	• Centrifuge not ready for operation.	▶ Press the Standby key.

9.2 Error messages

If an error message appears, proceed as follows:

- Remedy the fault as described in the "Solution" column.
- Press the **open** key to clear the error message from the display.
- If necessary, repeat centrifugation.

Code	Problem	Cause	Solution
LID		<ul style="list-style-type: none"> • The lid has not been released. 	<ul style="list-style-type: none"> ▶ Close the lid. ▶ Press the rotary knob start/stop. ▶ Open the lid using the emergency release, if required.
LID		<ul style="list-style-type: none"> • Lid has not been locked. 	<ul style="list-style-type: none"> ▶ Close the lid.
Er 2	Device does not start.	<ul style="list-style-type: none"> • Rotor is loaded asymmetrically. 	<ul style="list-style-type: none"> ▶ Load the rotor symmetrically.
Er 3	The centrifuge decelerates without braking.	<ul style="list-style-type: none"> • The tubes touch the centrifuge lid. 	<ul style="list-style-type: none"> ▶ Check the tubes. ▶ Switch off the device. ▶ Switch on the device and wait for approx. 5 min. ▶ Repeat the run.
Er 3-0	After switching on, the display shows Er 3.	<ul style="list-style-type: none"> • The tubes touch the centrifuge lid. 	
Er 3-2	The centrifuge decelerates with braking.	<ul style="list-style-type: none"> • Error in the electronics. 	
Er 3-3	The centrifuge decelerates without braking.	<ul style="list-style-type: none"> • Error in the electronics. 	<ul style="list-style-type: none"> ▶ Switch off the device. ▶ Switch on the device and wait for approx. 5 min. ▶ Repeat the run.
Er 5	The centrifuge decelerates without braking.	<ul style="list-style-type: none"> • Error in the lid latch. 	
Er 5-1 – Er 5-3	Run was started. The rotor rotates.	<ul style="list-style-type: none"> • Error in the lid latch. 	<ul style="list-style-type: none"> ▶ Close the lid. ▶ Repeat the run.
Er 6 – Er 6-6	The centrifuge decelerates without braking.	<ul style="list-style-type: none"> • Error in the electronics. 	
Er 7 – Er 7-2	The centrifuge decelerates without braking.	<ul style="list-style-type: none"> • The maximum speed of the rotor is exceeded. • The actual rotational speed of the rotor deviates from the set value. The tolerance is exceeded. 	<ul style="list-style-type: none"> ▶ Check if the mains/power supply voltage corresponds with the technical data.

Code	Problem	Cause	Solution
Er 8	The centrifuge brakes.	<ul style="list-style-type: none"> • Error occurs when the device accelerates or brakes. 	<ul style="list-style-type: none"> ▶ Repeat the run.
Er 9 – Er 9-4	The data of a run is not saved.	<ul style="list-style-type: none"> • Error in the electronics. 	
Er 10 – Er 10-5	The data of the last run is not saved.	<ul style="list-style-type: none"> • Error in the electronics. 	
Er 11	The centrifuge decelerates without braking.	<ul style="list-style-type: none"> • Mains/power outage during a run. • Error in the electronics. 	<ul style="list-style-type: none"> ▶ Check the mains/power cord. ▶ Repeat the run.
Er 14	The centrifuge can no longer be operated.	<ul style="list-style-type: none"> • Error in the electronics. 	<ul style="list-style-type: none"> ▶ Restart the device.
Er 15/Inb	The centrifuge switches off and decelerates without braking.	<ul style="list-style-type: none"> • Rotor is loaded asymmetrically. 	<ul style="list-style-type: none"> ▶ Load the rotor symmetrically. ▶ Repeat the run.
Er 16 – Er 16-2	The centrifuge switches off and decelerates without braking.	<ul style="list-style-type: none"> • Error in the electronics. 	<ul style="list-style-type: none"> ▶ Check the tubes. ▶ Switch off the device. ▶ Switch on the device and wait for 5 min. ▶ Repeat the run.
Er 17 – Er 17-2	The centrifuge switches off and decelerates without braking.	<ul style="list-style-type: none"> • Error in the electronics. 	<ul style="list-style-type: none"> ▶ Allow device to cool down. ▶ Repeat the run.
Er 18 – Er 18-3	The centrifuge switches off and decelerates without braking. (only Centrifuge 5702 R, Centrifuge 5702 RH)	<ul style="list-style-type: none"> • The temperature in the rotor chamber deviates from the set temperature by more than 5 °C. 	<ul style="list-style-type: none"> ▶ Check the ambient temperature. ▶ Check if the device is exposed to direct sunlight. ▶ Check if there is sufficient clearance around the device.
Er 19 – Er 19-1	The cooling aggregate is switched off. The fan continues to run. (only Centrifuge 5702 R, Centrifuge 5702 RH)	<ul style="list-style-type: none"> • Error in the cooling circuit. 	<ul style="list-style-type: none"> ▶ Check if the air can circulate through the ventilation slots. ▶ Check if there is sufficient clearance around the device.

Troubleshooting

Centrifuge 5702/5702 R/5702 RH
English (EN)

Code	Problem	Cause	Solution
Er 20	The centrifuge switches off and decelerates with braking. The cooling aggregate is switched off. (only Centrifuge 5702 R, Centrifuge 5702 RH)	<ul style="list-style-type: none"> • Error in the electronics 	<ul style="list-style-type: none"> ▶ Repeat the run.
Er 21	The centrifuge switches off and decelerates with braking.	<ul style="list-style-type: none"> • Error in the electronics 	
Er 22	The fan is switched. The error is only displayed if the centrifuge does not perform a run.	<ul style="list-style-type: none"> • Error in the electronics. 	<ul style="list-style-type: none"> ▶ The device can be used.
Er 23	The centrifuge decelerates without braking.	<ul style="list-style-type: none"> • The ambient temperature is too high. • The motor is too hot. 	<ul style="list-style-type: none"> ▶ Check the ambient temperature. ▶ Let the motor cool down. ▶ Repeat the run.
Er 24 – Er 24-3	The centrifuge switches off and decelerates with braking. (only Centrifuge 5702 R, Centrifuge 5702 RH)	<ul style="list-style-type: none"> • Error in the cooling aggregate. 	<ul style="list-style-type: none"> ▶ Allow device to cool down.
Er 25/Int		<ul style="list-style-type: none"> • Mains/power outage during a run. • The mains/power supply voltage fluctuates. • The mains/power supply voltage does not correspond with the technical data. 	<ul style="list-style-type: none"> ▶ Check the mains/power cord. ▶ Wait until the rotor stops rotating. ▶ Repeat the run.
Er 27		<ul style="list-style-type: none"> • Error in the electronics. 	<ul style="list-style-type: none"> ▶ Repeat the run.

9.3 Emergency release

If the centrifuge lid cannot be opened, you can activate the emergency release manually.



WARNING! Risk of injury from rotating rotor.

If the emergency release of the lid is operated, the rotor may continue rotating for several minutes.

- ▶ Wait for the rotor to stop before activating the emergency release.
 - ▶ To check, look through the monitoring glass in the centrifuge lid.
-

The emergency release consists of a cord with a plastic knob. The emergency release is located in the bottom panel at the front right device foot.

1. Disconnect the device from the mains/power supply.
2. Wait for the rotor to stop.
3. Push the centrifuge to the edge of the bench so that the bottom panel can be accessed from underneath at the front right device foot.
4. Remove the plastic button from the bottom panel.
5. Pull the cord downwards vertically.
The centrifuge lid opens.
6. To prepare the emergency release for its next use, push the cord all the way back into the housing.
7. Insert the plastic knob in the bottom panel.

Troubleshooting

Centrifuge 5702/5702 R/5702 RH
English (EN)

10 Transport, storage and disposal

10.1 Transport



CAUTION! Risk of injury when lifting and carrying heavy loads

The device is heavy. Lifting and carrying the device can lead to back injuries.

- ▶ Only lift and transport the device with a sufficient number of helpers.
- ▶ Use a transport aid for transporting the device.

- ▶ Remove the rotor from the centrifuge before transport.
- ▶ Use the original packing for transport.

	Air temperature	Relative humidity	Atmospheric pressure
General transport	-25 °C – 60 °C	10 % – 75 %	30 kPa – 106 kPa
Air freight	-20 °C – 55 °C	10 % – 75 %	30 kPa – 106 kPa

10.2 Storage

	Air temperature	Relative humidity	Atmospheric pressure
In transport packing	-25 °C – 55 °C	10 % – 75 %	70 kPa – 106 kPa
Without transport packing	-5 °C – 45 °C	10 % – 75 %	70 kPa – 106 kPa

10.3 Disposal

In case the product is to be disposed of, the relevant legal regulations are to be observed.

Information on the disposal of electrical and electronic devices in the European Community:

Within the European Community, the disposal of electrical devices is regulated by national regulations based on EU Directive 2012/19/EU pertaining to waste electrical and electronic equipment (WEEE).

According to these regulations, any devices supplied after August 13, 2005, in the business-to-business sphere, to which this product is assigned, may no longer be disposed of in municipal or domestic waste. To document this, they have been marked with the following identification:



Because disposal regulations may differ from one country to another within the EU, please contact your supplier if necessary.

11 Technical data

11.1 Power supply

	5702	5702 R	5702 RH
Mains/power connection	230 V, 50 Hz – 60 Hz 120 V, 50 Hz – 60 Hz 100 V, 50 Hz – 60 Hz	230 V, 50 Hz – 60 Hz 120 V, 50 Hz – 60 Hz 100 V, 50 Hz – 60 Hz	230 V, 50 Hz – 60 Hz 120 V, 50 Hz – 60 Hz 100 V, 50 Hz – 60 Hz
Current consumption	1.2 A (230 V) 2.3 A (120 V) 2.4 A (100 V)	1.7 A (230 V) 3.3 A (120 V) 3.5 A (100 V)	1.7 A (230 V) 3.3 A (120 V) 3.5 A (100 V)
Maximum power consumption	200 W	380 W	380 W
EMC: Interference emission. (radio interference)	EN 61326-1 – Class B (230 V) EN 61326-1 – Class A (120 V) FCC15 - Class A (120 V) EN 61326-1 – Class A (100 V)	EN 61326-1 – Class B (230 V) EN 61326-1 – Class A (120 V) FCC15 - Class A (120 V) EN 61326-1 – Class A (100 V)	EN 61326-1 – Class B (230 V) EN 61326-1 – Class A (120 V) FCC15 - Class A (120 V) EN 61326-1 – Class A (100 V)
EMC: Noise immunity	EN 61326	EN 61326	EN 61326
Overvoltage category	II	II	II
Fuses	2.5 AT (230 V) 5.0 AT (120 V) 5.0 AT (100 V)	2.5 AT (230 V) 5.0 AT (120 V) 6.3 AT (100 V)	2.5 AT (230 V) 5.0 AT (120 V) 6.3 AT (100 V)
Degree of pollution	2	2	2

11.2 Weight/dimensions

	5702	5702 R	5702 RH
Width	32.0 cm (12.59 in)	38.1 cm (15.00 in)	38.1 cm (15.00 in)
Depth	39.5 cm (15.55 in)	58.1 cm (22.87 in)	58.1 cm (15.00 in)
Height	24.3 cm (9.56 in)	27.0 cm (10.63 in)	27.0 cm (10.63 in)
Height with open lid	52.5 cm (20.67 in)	59.5 cm (10.63 in)	59.5 cm (23.43 in)
Weight without rotor	18.8 kg	35.1 kg	35.1 kg

Technical data

Centrifuge 5702/5702 R/5702 RH
English (EN)

11.3 Noise level

The noise level was measured according to (DIN EN ISO 3745) frontally in a sound measuring room with accuracy class 1 at a distance of 1 m from the device and at lab bench height.

	5702	5702 R	5702 RH
Noise level using rotor A-4-38	< 52 dB(A)	< 46 dB(A)	< 46 dB(A)

11.4 Ambient conditions

	5702	5702 R	5702 RH
Environment	For indoor use only.		
Ambient temperature	2 °C – 40 °C	10 °C – 40 °C	10 °C – 40 °C
Maximum relative humidity	75 %, non-condensing		
Atmospheric pressure	79.5 kPa – 106 kPa		

11.5 Application parameters

	5702	5702 R	5702 RH
Cycle time	0 s – 99 min, unlimited (∞) • Adjustable to 10 min in increments of 0.5 s, • from 10 min in increments of 1 min	0 s – 99 min, unlimited (∞) • Adjustable to 10 min in increments of 0.5 s, • from 10 min in increments of 1 min	0 s – 99 min, unlimited (∞) • Adjustable to 10 min in increments of 0.5 s, • from 10 min in increments of 1 min
Temperature	-	-9 °C – 40°C	-9 °C – 42 °C
Relative centrifugal force	100 × <i>g</i> – 3000 × <i>g</i> • can be set in increments of 100 × <i>g</i>	100 × <i>g</i> – 3000 × <i>g</i> • can be set in increments of 100 × <i>g</i>	100 × <i>g</i> – 3000 × <i>g</i> • can be set in increments of 100 × <i>g</i>
Rotational speed	100 rpm – 4 400 rpm • can be set in increments of 100 rpm	100 rpm – 4 400 rpm • can be set in increments of 100 rpm	100 rpm – 4 400 rpm • can be set in increments of 100 rpm
Maximum load	4 x 100 mL	4 x 100 mL	4 x 100 mL
Maximum kinetic energy	2 280 Nm	2 280 Nm	2 280 Nm
Permitted density of the material for centrifuging (at maximum <i>g</i> -force [rcf] and/or speed [rpm] and maximum load)	1.2 g/mL	1.2 g/mL	1.2 g/mL
Inspection obligation in Germany	no	no	no
Refrigerant	-	128 g (230 V) 122 g (120 V) 125 g (100 V)	132 g (230 V) 122 g (120 V) 125 g (100 V)

Technical data

Centrifuge 5702/5702 R/5702 RH
English (EN)

11.6 Acceleration and deceleration times

The following table contains approximate acceleration times and deceleration times in accordance with DIN 58970. The values are for guidance only. Fluctuations may occur depending on the condition of the device and the load.

Rotor		Centrifuge 5702		Centrifuge 5702 R		Centrifuge 5702 RH	
			Soft ramp		Soft ramp		Soft ramp
A-4-38 with round bucket	Acceleration time	19 s	1:38 min	16 s	1:37 min	16 s	1:37 min
	Deceleration time	18 s	1:31 min	22 s	1:33 min	23 s	1:32 min
	Tolerance	±5 %, 5 s minimum					
A-4-38 with rectangular buckets	Acceleration time	18 s	1:38 min	16 s	1:37 min	16 s	1:37 min
	Deceleration time	19 s	1:30 min	22 s	1:33 min	22 s	1:32 min
	Tolerance	±5 %, 5 s minimum					
A-8-17	Acceleration time	14 s	1:37 min	15 s	1:37 min	15 s	1:37 min
	Deceleration time	17 s	1:34 min	19 s	1:35 min	19 s	1:33 min
	Tolerance	±5 %, 5 s minimum					
FA-45-24-11	Acceleration time	13 s	1:36 min	14 s	1:36 min	15 s	1:37 min
	Deceleration time	16 s	1:32 min	19 s	1:36 min	19 s	1:32 min
	Tolerance	±5 %, 5 s minimum					
F-35-30-17	Acceleration time	17 s	1:41 min	20 s	1:38 min	19 s	1:38 min
	Deceleration time	17 s	1:30 min	28 s	1:30 min	29 s	1:29 min
	Tolerance	±5 %, 5 s minimum					

11.7 Service life for accessories



CAUTION! Danger due to material fatigue.

If the service life is exceeded, it cannot be guaranteed that the material of the rotors and the accessories will withstand the stresses during centrifugation.

- ▶ Do not use any accessories which have exceeded their maximum service life.

The following requirements must be met in order to use rotors, rotor lids and accessories:

- Proper use
- Recommended maintenance
- Undamaged condition

The service life of rotors and accessories is indicated by two values:

- Service life in years from initial setup
- Maximum number of cycles

The decisive factor for the service life is which case occurs first, usually this is the number of years in operation.

A cycle is a centrifugation run during which a rotor accelerates and is braked. The speed and the duration of the centrifugation run do not matter.

Rotor/accessories	Maximum number of cycles	Maximum service life in years
Rotor A-4-38	100000	10 years
Rotor A-8-17	75000	7 years
Bucket for rotor A-4-38	100000	7 years
Aerosol-tight caps made from polycarbonate (PC) for round buckets	50 autoclaving cycles	3 years
Plastic adapters		1 year
Adapters	–	1 year

For the other rotors and rotor lids of this centrifuge there is no limit for the service life.

The date of manufacture is stamped on the rotors in the format *03/10* (= March 2010) or on the inside of the plastic rotor lids and caps in the form of a clock ⌚. This is for information only and does not have any reference to the service life.

Technical data

Centrifuge 5702/5702 R/5702 RH

English (EN)

12 Rotors, tubes and adapters





Eppendorf centrifuges may only be operated with rotors that are intended for use with the corresponding centrifuge.



- ▶ Only use rotors which are marked with the name of the centrifuge (e.g., 5702).

Please note the manufacturer's information on the centrifugation resistance of the sample tubes used (maximum *g*-force).

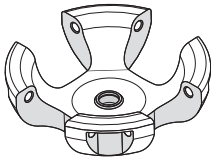
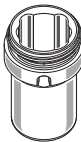
12.1 Rotor A-4-38





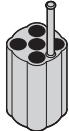
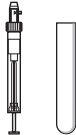

12.1.1 Rotor A-4-38 with 4 round buckets



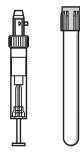
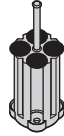
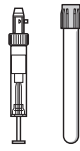

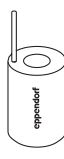
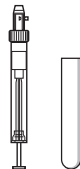
			Max. <i>g</i> -force:	3000 × <i>g</i>
			Max. speed:	4400 rpm
Rotor A-4-38	Round bucket 5702 722.006 5702 761.001	Aerosol-tight cap 5702 721.000	Max. load per bucket (adapter, tube and contents):	190 g

Tube	Tube Capacity Number per adapter/rotor	Adapter Order no. (international)	Bottom shape Diameter Max. tube length with/without aerosol-tight cap	Max. <i>g</i> -force Max. speed Radius
	Micro test tube 1.5 mL – 2 mL 4/16	 5702 745.006	round Ø 11 mm 43 mm/43 mm	2900 × <i>g</i> 4400 rpm 13.4 cm
	Micro test tube 1.1 mL – 1.4 mL 5/20	 5702 736.007	flat Ø 8.5 mm 100 mm/100 mm	2850 × <i>g</i> 4400 rpm 13.2 cm
	Micro test tube 2 mL – 7 mL 5/20	 5702 737.003 5702 741.000	flat Ø 12.5 mm 100 mm/100 mm	2850 × <i>g</i> 4400 rpm 13.2 cm

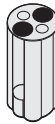
Rotors, tubes and adapters

Centrifuge 5702/5702 R/5702 RH
English (EN)

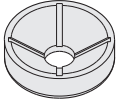

Tube	Tube Capacity Number per adapter/rotor	Adapter Order no. (international)	Bottom shape Diameter Max. tube length with/without aerosol-tight cap	Max. <i>g</i> -force Max. speed Radius
	Micro test tube 2.6 mL – 7 mL 4/16	 5702 719.005 5702 741.000	flat Ø 13.5 mm 100 mm/100 mm	2850 × <i>g</i> 4400 rpm 13.2 cm
	Micro test tube 4 mL – 10 mL 4/16	 5702 735.000 5702 742.007	flat Ø 16 mm 100 mm/100 mm	2850 × <i>g</i> 4400 rpm 13.2 cm
	Micro test tube 5 mL 1/4	 5702 733.008	flat Ø 17 mm 60 mm/60 mm	2943 × <i>g</i> 4400 rpm 13.6 cm
	Micro test tube 9 mL – 15 mL 4/16	 5702 724.009 5702 749.007	round Ø 17.5 mm 100 mm/100 mm	2800 × <i>g</i> 4400 rpm 13.0 cm
	Micro test tube 15 mL 1/4	 5702 732.001	conical Ø 17.2 mm 120 mm/121 mm	3000 × <i>g</i> 4400 rpm 13.7 cm
	Micro test tube 15 mL 2/8	 5702 723.002	conical Ø 17.2 mm -/121 mm	3000 × <i>g</i> 4400 rpm 13.7 cm







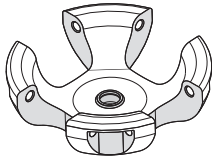

Tube	Tube Capacity Number per adapter/rotor	Adapter Order no. (international)	Bottom shape Diameter Max. tube length with/without aerosol-tight cap	Max. <i>g</i> -force Max. speed Radius
	Micro test tube 25 mL 1/4	 5702 717.002	round Ø 25 mm 100 mm/100 mm	2900 × <i>g</i> 4400 rpm 13.5 cm
	Micro test tube 50 mL 1/4	 5702 734.004	conical Ø 30 mm 115 mm/115 mm	2900 × <i>g</i> 4400 rpm 13.5 cm
	Micro test tube 100 mL 1/4	 5702 718.009	round Ø 38 mm 106 mm/106 mm	2900 × <i>g</i> 4400 rpm 13.5 cm

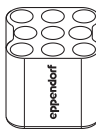

Rotors, tubes and adapters

Centrifuge 5702/5702 R/5702 RH
English (EN)

12.1.2 Rotor A-4-38 with 4 rectangular buckets

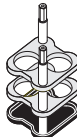

		Max. <i>g</i> -force:	2750 × <i>g</i>
		Max. speed:	4400 rpm
Rotor A-4-38	Rectangular bucket 5702 709.000 5702 762.008	Max. load per bucket (adapter, tube and contents):	240 g

Tube	Tube Capacity Number per adapter/rotor	Adapter Order no. (international)	Bottom shape Diameter Max. tube length	Max. <i>g</i> -force Max. speed Radius
	Micro test tube Cultivation vessel 5 mL 9/36	 5702 763.004	round Ø 12 mm 75 mm	2577 × <i>g</i> 4400 rpm 11.9 cm
	Micro test tube 5 mL – 7 mL 10/40	 5702 710.008	flat Ø 13 mm 100 mm	2750 × <i>g</i> 4400 rpm 12.7 cm
	Micro test tube 9 mL 8/32	 5702 711.004	flat Ø 14.5 mm 100 mm	2750 × <i>g</i> 4400 rpm 12.7 cm
	Micro test tube 15 mL 6/24	 5702 712.000	flat Ø 17.5 mm 100 mm	2750 × <i>g</i> 4400 rpm 12.7 cm
	Micro test tube 25 mL 2/8	 5702 716.006	flat Ø 25 mm 100 mm	2750 × <i>g</i> 4400 rpm 12.7 cm

Tube	Tube Capacity Number per adapter/rotor	Adapter Order no. (international)	Bottom shape Diameter Max. tube length	Max. <i>g</i> -force Max. speed Radius
	Micro test tube 20 mL 4/16	 5702 713.007	flat Ø 22 mm 100 mm	2750 × <i>g</i> 4400 rpm 12.7 cm

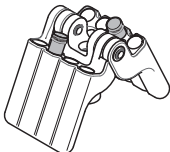

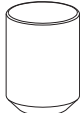



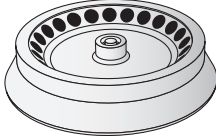

12.2 Rotor A-8-17

	Max. <i>g</i> -force:	2800 × <i>g</i>
	Max. speed:	4400 rpm
Rotor A-8-17	Max. load per bucket (adapter, tube and contents):	38 g

Tube	Tube Capacity Number per adapter/rotor	Adapter Order no. (international)	Bottom shape Diameter Max. tube length	Max. <i>g</i> -Zahl Max. speed Radius
	Micro test tube 15 mL 1/8	 5702 702.005	conical Ø 17.2 mm 120 mm	2 770 × <i>g</i> 4400 rpm 12.8 cm
	Micro test tube 15 mL 1/8	 5702 701.009	round Ø 17.5 mm 120 mm	2 770 × <i>g</i> 4400 rpm 12.8 cm





12.3 Rotor F-45-24-11

	Max. <i>g</i> -force:	1770 × <i>g</i>
	Max. speed:	4400 rpm
F-45-24-11	Max. load per bucket (adapter, tube and contents):	8.70 g

Tube	Tube Capacity Number per adapter/rotor	Adapter Order no. (international)	Bottom shape Diameter Max. tube length with/without rotor lid	Max. <i>g</i> -force Max. speed Radius
	Micro test tube 1.5/2 mL -/24	-	- Ø 11 mm	1770 × <i>g</i> 4400 rpm 8.2 cm
	PCR tube 0.2 mL 1/24	 5425 715.005	Conical Ø 6 mm	1 430 × <i>g</i> 4400 rpm 6.6 cm
	Micro test tube 0.4 mL 1/24	 5425 717.008	Conical Ø 6 mm	1770 × <i>g</i> 4400 rpm 8.2 cm
	Micro test tube 0.5 mL – 0.6 mL 1/24	 5425 716.001	- Ø 8 mm	1 600 × <i>g</i> 4400 rpm 7.5 cm
	Microtainers 0.6 mL 1/24	 5425 716.001	- Ø 8 mm 47 mm/64 mm	1 600 × <i>g</i> 4400 rpm 7.5 cm





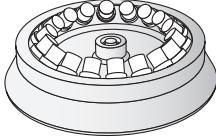

12.4 Rotor F-35-30-17

	Max. <i>g</i> -force:	2750 × <i>g</i>
	Max. speed:	4400 rpm
Rotor F-35-30-17	Max. load (adapter, tube and contents):	56 g

Tube	Tube Capacity Number per adapter/rotor	Adapter Order no. (international)	Bottom shape Diameter Max. tube length	Max. <i>g</i> -force
				Outer ring Center ring Inner ring
				Max. speed
				Radius Outer ring Center ring Inner ring
	Micro test tube			-
	1.5 mL – 2 mL 1/10		Ø 11 mm	- 1450 × <i>g</i> 4400 rpm - - 6.7 cm
	Micro test tube	 5702 707.007 5702 706.000	conical	2750 × <i>g</i> 2300 × <i>g</i> -
	15 mL 1/20		Ø 16.2 mm	4400 rpm 12.7 cm 10,7 cm -
	Micro test tube	 5702 707.007 5702 708.003	round	2750 × <i>g</i> 2300 × <i>g</i> -
	15 mL 1/30		Ø 16.2 mm	4400 rpm 12.7 cm 10,7 cm -

12.5 Rotor F-45-18-17-Cryo

	Max. <i>g</i> -force:	1970 × <i>g</i>
	Max. speed:	4400 rpm
F-45-18-17-Cryo	Max. load (adapter, tube and contents):	8.70 g

Tube	Tube Capacity Number per adapter/rotor	Adapter Order no. (international)	Bottom shape Diameter Max. tube length with rotor lid	Max. <i>g</i> -force Max. speed Radius
	Vessel with screw cap 1 mL – 2 mL -/17	–	flat Ø 17 mm 50 mm	1970 × <i>g</i> 4400 rpm 9.1 cm
	Cryo tube 1 mL – 2 mL 1/17	 5702 752.002	Ø 13 mm 50 mm	1930 × <i>g</i> 4400 rpm 8.9 cm
	Tube with lid 1/17	 5702 752.002	Ø 12.2 mm 50 mm	1930 × <i>g</i> 4400 rpm 8.9 cm
	HPLC vessel 1.5 mL 1/17	 5427 708.006	Ø 16.5 mm 50 mm	1930 × <i>g</i> 4400 rpm 8.9 cm

13 Ordering information
13.1 Rotor A-4-38
13.1.1 Rotor A-4-38 with round buckets

Order no. (International)	Description
5702 720.003	Rotor A-4-38 8 positions, max. Ø 38 mm with 4 round buckets, 100 ml
5702 761.001 5702 722.006	Round bucket 100 mL for rotor A-4-38 2 pieces 4 pieces
5702 721.000	Aerosol-tight cap for 100 mL round buckets 2 pieces
5702 745.006 5702 736.007 5702 737.003 5702 719.005 5702 735.000 5702 724.009 5702 732.001 5702 723.002 5702 717.002 5702 734.004 5702 718.009 5702 733.008	Adapter for 100 mL round bucket for use with standard and blood collection tubes, (number × tube volume, Ø adapter bore × max. tube length) 4 × 1.5/2.0 mL tubes, set of 2 5 × 1 – 1.4 mL, 8.5 mm × 100 mm, 2 pcs 5 × 2 – 7 mL, 12.5 mm × 100 mm, set of 2 4 × 2.6 - 7 mL, 13.5 mm × 100 mm, set of 2 4 × 4 – 10 mL, 16 mm × 100 mm, set of 2 4 × 9 - 15 mL, 17.5 mm × 100 mm, set of 2 1 × 15 mL conical tube, 17.2 mm × 121 mm, set of 2 2 × 15 mL conical tubes, 17.2 mm × 121 mm, set of 2* 1 × 25 mL, 25 mm × 100 mm, set of 2 1 × 50 mL conical tube, 30 mm × 115 mm, set of 2 1 × 100 mL, 38 mm × 106 mm, set of 2 1 × 5 mL, 17 mm × 60 mm, set of 2
5702 741.000	Rubber mat for adapter 5702 737.003, 5702 719.005 7 mL, 20 pieces
5702 742.007	Rubber mat for adapter 5702 735.000 10 mL, 20 pieces
5702 749.007	Rubber mat for adapter 5702 724.009 15 mL, 20 pieces

* Cannot be used with aerosol-tight caps.

Ordering information

Centrifuge 5702/5702 R/5702 RH
English (EN)

13.1.2 Rotor A-4-38 with rectangular buckets

Order no. (International)	Description
5702 740.004	Rotor A-4-38 8 positions, max. Ø 38 mm without buckets
5702 762.008 5702 709.000	Rectangular bucket 90 mL for rotor A-4-38 2 pieces 4 pieces
5702 710.008 5702 711.004 5702 712.000 5702 713.007 5702 716.006 5702 763.004	Adapter for 90 mL rectangular bucket for use with standard tubes, (number × tube volume, Ø adapter bore × max. tube length) 10 × 5 – 7 mL, 13 mm × 100 mm, set of 2 8 × 9 mL, 14.5 mm × 100 mm, set of 2 6 × 15 mL, 17.5 mm × 100 mm, set of 2 4 × 20 mL, 22 mm × 100 mm, set of 2 2 × 25 mL, 25 mm × 100 mm, set of 2 9 × XX mL, 12 mm × 100 mm, set of 2

13.2 Rotor A-8-17

Order no. (International)	Description
5702 700.002	Rotor A-8-17 8 positions, max. Ø 17 mm for 15 mL vessels
5702 702.005	Adapter for rotor A-8-17 for conical tubes 15 mL, 8 pieces
5702 701.009	Rubber mat for rotor A-8-17 15 mL round-bottom tubes, 8 pieces

13.3 Rotor F-45-24-11

Order no. (International)	Description
5702 746.002	Rotor F-45-24-11 45° angle, 24 places, max. Ø 11 mm without lid
5425 715.005	Adapter used in FA-45-48-11, F-45-48-11, FA-45-30-11, F-45-30-11, F-45-24-11, F-45-70-11, FA-45-24-11, FA-45-24-11-Special, FA-45-24-11-HS and FA-45-24-11-Kit for 1 PCR tube (0.2 mL, max. Ø 6 mm), set of 6
5425 717.008	Adapter used in FA-45-48-11, F-45-48-11, F-45-12-11, FA-45-18-11, FA-45-30-11, F-45-30-11, F-45-24-11, F-45-70-11, FA-45-24-11-HS, FA-45-24-11-Kit and S-24-11-AT for 1 micro test tube (0.4 mL, max. Ø 6 mm), set of 6
5425 716.001	Adapter used in FA-45-48-11, F-45-48-11, FA-45-30-11, F-45-30-11, F-45-48-11, F-45-70-11, FA-45-24-11, FA-45-24-11-Special, FA-45-24-11-HS and FA-45-24-11-Kit for 1 sample tube (0.5 mL, max. Ø 6 mm) or 1 Microtainer (0.6 mL, max. Ø 8 mm), set of 6

13.4 Rotor F-35-30-17

Order no. (International)	Description
5702 704.008	Rotor F-35-30-17 35° angle, 30 places, max. Ø 17 mm incl. 30 steel sleeves for 15 mL vessels, 20 Adapters for conical tubes and 30 rubber mats
5702 705.004	incl. 10 steel sleeves for 15 ml vessels, 10 Adapters for conical tubes and 10 rubber mats
5702 707.007	Steel sleeve for rotor F-35-30-17 15 mL, 10 pieces
5702 706.000	Adapter used in F-35-30-17 for conical tubes 15 mL, 10 pieces
5702 708.003	Rubber mat for rotor F-35-30-17 15 mL round-bottom tubes, 10 pieces

Ordering information

Centrifuge 5702/5702 R/5702 RH
English (EN)

13.5 Rotor F-45-18-17-Cryo

Order no. (International)	Description
5702 747.009	Rotor F-45-18-17-Cryo angle 45°, 18 places, max. Ø 17 mm, max. length 50 mm for cryo tubes and sealable centrifugation tubes, without rotor lid, without adapter
5702 752.002	Adapter used in F-45-18-17-Cryo for cryo tubes (max. Ø 13 mm) and sealable centrifuge tubes (max. Ø 12.2 mm), max. length 50 mm, set of 6
5427 708.006	for 1.5 mL HPLC vials, 18 pieces

13.6 Fuses

Order no. (International)	Description
5425 351.003	Fuse 2.5 A T (230 V), set of 2
5425 353.006	5 A T (100V/120 V), UL, set of 2
5703 851.136	6.3 AT (100 V), 2 pieces

Index

A

Aborting.....35
 Aborting centrifugation.....35
 Acceleration ramp43, 62
 Acceleration times.....62
 Aerosol-tight cap32
 Aerosol-tight centrifugation32, 33
 At set rpm.....36, 43

B

Braking ramp.....43, 62

C

Centrifugation time34
 Centrifuge
 Switching off the centrifuge.....40
 Centrifuge lid
 Closing the centrifuge lid.....33
 Spring.....40
 Cleaning46
 Close.....33
 Continuous run.....35
 Controlling.....34
 Controlling centrifugation34
 Cycle time
 Cycle time flashes35
 Setting the cycle time34

D

Deceleration times.....62
 Decontamination49
 Disinfection46
 Disposal58

E

End of centrifugation 35
 Equipping buckets 31

G

g-force
 Setting the g-force..... 34

I

Imbalance calibration 30
 Inserting the rotor..... 28
 Installation
 Selecting the location..... 21

K

Key lock..... 41

L

Lid
 Closing the lid..... 33
 Spring 40
 Loading a rotor
 Fixed-angle rotor..... 29
 Swing-bucket rotor 30

M

Mains/power connection 21

P

Program
 Calling up a program..... 44
 Creating a program 43
 Editing programs..... 44
 Program key 43
 Storing a program 43, 43

Index

Centrifuge 5702/5702 R/5702 RH
English (EN)

R

Ramp	36, 62
rcf	
Setting rcf.....	34
Removing the rotor.....	28
Rotational speed	
Setting the rotational speed.....	34
Rotor	
Cleaning the rotor	47
Rotor replacement.....	28
rpm	
Setting rpm	34





























S

Selecting the location	21
Short Spin.....	35
Short spin centrifugation.....	35
Soft ramp	36
Speakers	42
Speed.....	34
Spring of the centrifuge lid	40
Standby.....	41
Starting.....	34
Starting centrifugation	34
Storage	57
Switching off	40

T

Temperature	34
Time	
Setting the time.....	34
Time flashes	35
Time counting	
Beginning of time counting	36

Annex Shortcuts

Task	Lid	Key	Display 5702	Display 5702 R	Display 5702 RH
Modifying parameters during centrifugation Chapter 5.8		 > 2 s	Display flashes 5 s.	Display flashes 5 s.	Display flashes 5 s.
Setting a soft ramp Chapter 5.8		 > 5 s	<i>br on</i> <i>br OF</i>	No symbol 	No symbol 
Switching on/off the speakers Chapter 6.3		 > 2 s	<i>b on</i> <i>b OF</i>	 No symbol	 No symbol
Setting a key lock Chapter 6.2		 +  > 2 s	<i>lo on</i> <i>blo OF</i>	 	 
Calling up a program Chapter 7.3	 	1. Set parameter  or  > 2 s	-	<i>Pr 1</i> <i>Pr 2</i>	<i>Pr 1</i> <i>Pr 2</i>
Setting the beginning of time counting (At set rpm function) Chapter 5.8		 > 2 s	 	 	 

Shortcuts

Centrifuge 5702/5702 R/5702 RH

Declaration of Conformity

The product named below fulfills the requirements of directives and standards listed. In the case of unauthorized modifications to the product or an unintended use this declaration becomes invalid. This declaration of conformity is issued under the sole responsibility of the manufacturer.

Product name:

Centrifuge 5702, Centrifuge 5702 R, Centrifuge 5702 RH
including components

Product type:

Centrifuge

Relevant directives / standards:

2014/35/EU: EN 61010-1, EN 61010-2-020, EN 61010-2-010 (only 5702 RH)
UL 61010-1, CAN/CSA C22.2 No. 61010-1, IEC 61010-2-020

2014/30/EU: EN 61326-1, EN 55011
CFR 47 FCC part 15 class A

98/79/EC: EN ISO 14971, EN 61010-2-101, EN 61326-2-6, EN 62366,
EN 18113-1, EN 18113-3, EN 15223-1

2014/68/EU: EN 378-1, EN 378-2 (only 5702 R, 5702 RH)

2011/65/EU: EN 50581

Hamburg, August 15, 2017



Dr. Wilhelm Plüster
Management Board



Dr. Reza Hashemi
Portfolio Management

Your local distributor: www.eppendorf.com/contact
Eppendorf AG · Barkhausenweg 1 · 22339 Hamburg · Germany
eppendorf@eppendorf.com

Eppendorf® and the Eppendorf Brand Design are registered trademarks of Eppendorf AG, Germany.
All rights reserved, incl. graphics and pictures. Copyright ©2017 by Eppendorf AG.

www.eppendorf.com

ISO
9001
Certified

ISO
13485
Certified

ISO
14001
Certified

5703 900.307-07

CERTIFICATE OF COMPLIANCE

Certificate Number 20120416 – E215059
Report Reference E215059 – 2002 February 28
Issue Date 2012 April 16
Issued to: EPPENDORF ZENTRIFUGEN GMBH
RIESAER STR 198
04319 LEIPZIG, GERMANY

This is to certify that representative samples of

Laboratory-use Electrical Equipment
Centrifuge, Model 5702.

Have been investigated by UL in accordance with the Standard(s) indicated on this Certificate.

Standard(s) for Safety:

ANSI/UL 61010-1, "Electrical Equipment for Measurement, Control and Laboratory Use - Part 1: General Requirements" and C22.2 No. 1010.1 (1992), "Safety Requirements for Electrical Equipment for Measurement, Control, and Laboratory Use, Part I: General Requirements." Part 2: Particular Requirements for Laboratory Centrifuges, CAN/CSA-C22.2 No. 1010.2.020-92, CAN/CSA-C22.2 No. 1010.2.020A-97

Additional Information:

See the UL Online Certifications Directory at www.ul.com/database for additional information

Only those products bearing the UL Listing Mark for the US and Canada should be considered as being covered by UL's Listing and Follow-Up Service meeting the appropriate requirements for US and Canada.

The UL Listing Mark for the US and Canada generally includes: the UL in a circle symbol with "C" and "US" identifiers:

 the word "LISTED"; a control number (may be alphanumeric) assigned by UL; and the product category name (product identifier) as indicated in the appropriate UL Directory.

Look for the UL Listing Mark on the product.

William R. Carney, Director, North American Certification Programs

UL LLC

Any information and documentation involving UL Mark services are provided on behalf of UL LLC (UL) or any authorized licensee of UL. For questions, please contact a local UL Customer Service Representative at www.ul.com/contactus



CERTIFICATE OF COMPLIANCE

Certificate Number 20120416 – E215059
Report Reference E215059 – 2002 August 27
Issue Date 2012 April 16
Issued to: EPPENDORF ZENTRIFUGEN GMBH
RIESAER STR 198
04319 LEIPZIG, GERMANY

This is to certify that representative samples of

Laboratory-use Electrical Equipment
Centrifuge, Model 5702R, 5703 and 5702RH, 5704.

Have been investigated by UL in accordance with the Standard(s) indicated on this Certificate.

Standard(s) for Safety: ANSI/UL 61010-1, "Electrical Equipment for Measurement, Control and Laboratory Use - Part 1: General Requirements" and C22.2 No. 1010.1 (1992), "Safety Requirements for Electrical Equipment for Measurement, Control, and Laboratory Use, Part I: General Requirements." Part 2: Particular Requirements for Laboratory Centrifuges, CAN/CSA-C22.2 No. 1010.2.020-92, CAN/CSA-C22.2 No. 1010.2.020A-97

Additional Information: See the UL Online Certifications Directory at www.ul.com/database for additional information

Only those products bearing the UL Listing Mark for the US and Canada should be considered as being covered by UL's Listing and Follow-Up Service meeting the appropriate requirements for US and Canada.

The UL Listing Mark for the US and Canada generally includes: the UL in a circle symbol with "C" and "US" identifiers:

 the word "LISTED"; a control number (may be alphanumeric) assigned by UL; and the product category name (product identifier) as indicated in the appropriate UL Directory.

Look for the UL Listing Mark on the product.

William R. Carney, Director, North American Certification Programs

UL LLC

Any information and documentation involving UL Mark services are provided on behalf of UL LLC (UL) or any authorized licensee of UL. For questions, please contact a local UL Customer Service Representative at www.ul.com/contactus



© CAMR The contents of this report may not be abstracted, published or used for advertising without permission.

Containment Testing of the Sealed Buckets For The A-4-38 Rotor in the Eppendorf 5702 Bench Top Centrifuge

Report 769/02

Commercial in Confidence

CAMR Ref.	Project No. 769/02
Customer Ref.	620-804158
Report Prepared For	Ms. Sylke Grun
Operator	Ms Carolyn Budge
Issue Date	27th August 2002
Number of Copies	1
Distribution	Ms. S Grun, Mr. A. Bennett, Central Records (Dr. P. Hammond)

Report Checked By

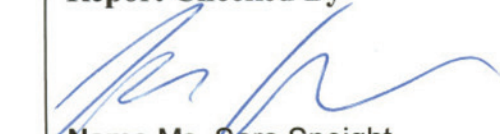

Name Ms. Sara Speight
Title Research Scientist

Authorised And Written By



Name Mr Allan Bennett
Title Head of Biosafety Investigation Unit

Evaluate Your Manual

Give us your feedback.
www.eppendorf.com/manualfeedback



Eppendorf AG
Barkhausenweg 1
22339 Hamburg
Germany

Your local distributor: www.eppendorf.com/contact
eppendorf@eppendorf.com · www.eppendorf.com